

Installation Manual

BKO 42-42

©2025

BRUNNER[®]

CONTENTS

1	General information.....	4
1.1	Raw steel cladding.....	4
1.1.1	Care instructions.....	4
1.2	Tolerances of thermal concrete parts.....	7
2	Safety.....	9
2.1	Safety precautions.....	9
2.2	Heat radiation range.....	10
2.3	Minimal distances.....	11
3	Installation.....	12
3.1	Setting up.....	12
3.1.1	Base plate.....	13
3.1.1.1	Components Base plate.....	13
3.1.1.2	Set up the fireplace.....	14
3.1.2	Adjustment.....	15
3.2	Cladding frame.....	19
3.2.1	Components Cladding frame.....	19
3.2.2	Installing Cladding frame.....	20
3.3	Cladding.....	33
3.3.1	Components of Cladding.....	33
3.3.2	Installing of Cladding pannels.....	33
3.4	side-opening door.....	37
3.5	deflection.....	38
3.6	Variants Combustion chamber lining.....	40
3.6.1	Chamotte inner lining.....	40
3.6.2	Combustion chamber inner lining cast iron.....	41
3.7	Variant Supply air connection box ø 125 mm.....	43
3.8	Variants heat exchanger.....	44
3.8.1	Cast iron heat exchanger rings.....	44
3.8.1.1	Components Set 2 heat exchanger rings.....	44
3.8.1.2	Fitting the heat exchanger rings.....	45
3.8.2	MAS.....	51
3.8.2.1	Components MAS.....	51
3.8.2.2	MAS assembly.....	52
3.9	Variant EAS or EOS.....	54
3.9.1	Bottom cover air box EOS.....	54
3.9.1.1	Components EOS.....	54
3.9.1.2	Fitting: EOS.....	55
3.9.1.3	Membrane feed-through.....	56
3.9.1.4	Air position indicator BKH flat.....	57
3.9.2	EAS3.....	58
3.9.2.1	Components EAS.....	58
3.9.2.2	Fitting: EAS.....	59
3.9.3	Thermocouple.....	61

3.9.3.1	Components Thermocouple.....	61
3.9.3.2	Fitting: Thermocouple.....	62
3.9.4	Door contact switch.....	64
3.9.4.1	Components Door contact switch.....	64
3.9.4.2	Fitting: Door contact switch.....	65
4	Technical data.....	67

1 GENERAL INFORMATION

1.1 RAW STEEL CLADDING

Our BRUNNER BKO with its special raw steel cladding embodies the interplay of precision craftsmanship and natural aesthetics. With a timelessly elegant look, it becomes an expressive highlight in modern and rustic living concepts. In industrial design in particular, raw steel is a central element that accentuates urban charm and modern loft style.

Raw steel is steel in its most original form, whose unique surface is created by a special rolling process at high temperatures. During this process, a hard layer of iron oxide, also known as scale, forms, giving the material its characteristic black-blue color. In combination with its irregular, organic structure, in which small color nuances and individual patterns become visible, each BKO is visually unique.

With the right care of the raw steel, the surface is preserved for a long time and develops an individual appearance over time, giving your stove additional personality.

1.1.1 CARE INSTRUCTIONS

Careful care of the raw steel is essential to maintain the BKO cladding in the long term. The best possible protection of the surface can be ensured by observing the following care instructions, which will keep it in optimum condition in terms of appearance and quality.

1. protection from moisture

Moisture has a negative effect on the raw steel as it can lead to rust formation. The surface can therefore be effectively protected against moisture:

Observe the humidity in the installation area

- Ensure moderate humidity in the installation room (ideally between 40 - 60 %).
- Avoid strongly fluctuating humidity conditions (e.g. longer ventilation periods in winter).
- Use in swimming pools and damp rooms is not recommended.
- The product is not suitable for outdoor use.

Remove spilled liquids immediately

- Avoid direct contact of liquids (water, drinks, etc.) with the surface.
- If liquids get onto the surface, wipe them up immediately with a soft, dry cloth.

Avoid skin contact

- Avoid direct skin contact with the surface, as fingerprints and handprints can otherwise leave stains.
- Always wear gloves when touching the cladding.

2. after-treatment of the surface

Post-treatment with anti-corrosion oil is a simple way of protecting the cladding from rust and sealing the raw steel.

Frequency of post-treatment

- Re-treatment should be carried out as required, usually once or twice a year.
- If necessary: If changes to the surface become visible (e.g. slight stains or matt sheen)

Preparing the surface

- Clean the surface thoroughly before applying the oil.
- Wipe off dust and dirt with a dry cloth.
- Ensure that the surface is completely dry.

Applying oil

- Spread a small amount of anti-corrosion oil onto a soft, lint-free cloth.
- Apply a thin, even layer to the surface.
- Less is more - too much oil can leave unsightly streaks.
- Then lightly polish the surface with a dry cloth.

3. regular and correct cleaning

Regular cleaning is important to keep the surface looking attractive.

Remove dust and dirt

- Wipe the surface regularly with a soft, dry cloth.
- Alternatively, a vacuum cleaner with a soft brush nozzle can be used to remove dust.

Do not use aggressive cleaning agents

- Never use aggressive cleaning agents, scouring milk or steel wool!
- This will permanently damage the surface, which can impair protection against corrosion.

4. avoid scratches

Raw steel is robust, but can be scratched by mechanical influences.

Do not lean on any objects

- Avoid leaning objects (e.g. everyday objects, tools, etc.) against the cladding, as this can leave scratches and dents.

Keep the cover clear

- Do not use the lid as a storage surface.
- Small objects such as keys or decorations can also scratch the surface.

1.2 TOLERANCES OF THERMAL CONCRETE PARTS

The following tolerances are valid for all parts of our system fireplace/stove casings. Except where otherwise indicated, all data refer to the nominal dimensions, as found in dimensional drawings.

Length Tolerances

For each part, the indicated tolerances apply.

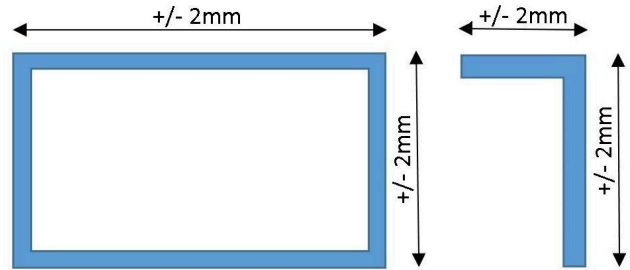

Height Tolerances

For each part, the indicated tolerances apply.

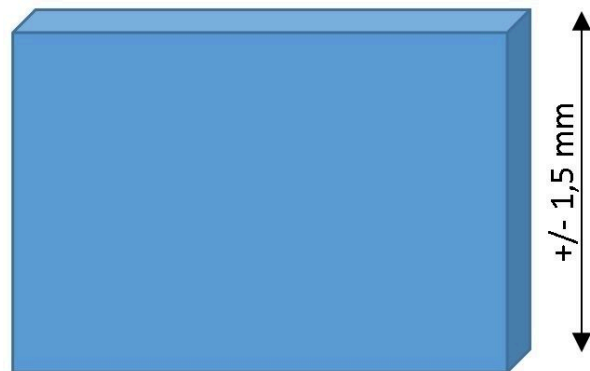

Tolerances of Flatness

For parts with nominal dimensions up to 950 mm, a tolerance of +/- 2.5 mm applies. Above this dimension, a tolerance of +/- 3 mm applies.

These tolerances apply also for the base support and top cover parts. The leveling board (R) must be placed in parallel to the basic body!

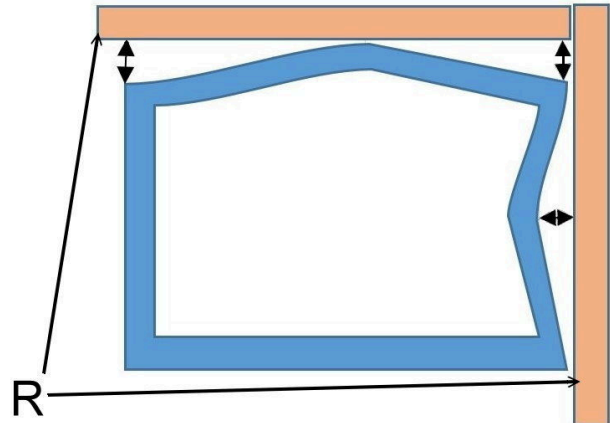

Im. 1: Leveling boards placed correctly

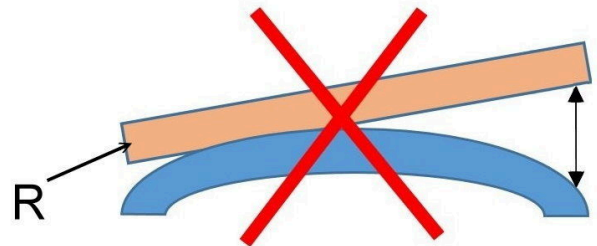

Im. 2: Incorrectly placed leveling board

Tolerances of Angle

In order to determine the deviations of angles, place the square measuring tool along the long edge!

For nominal dimensions up to 600 mm, a tolerance of 0.28%, i.e. 1.7 mm applies. For nominal dimensions up to 900 mm, a tolerance of 0.30%, i.e. 2.4 mm applies.

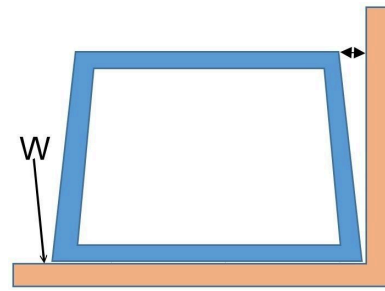

Roundness

Up to a nominal diameter of 650 mm, a tolerance of 0.25%, i.e. 1.62 mm applies. For diameters above this value, a tolerance of 0.28%, i.e. 2.38 mm applies.

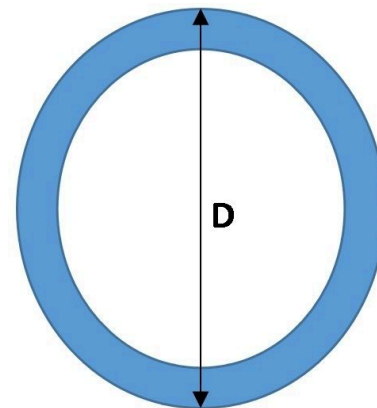

Wall thicknesses

For wall thicknesses, a tolerance of 3.5% applies.

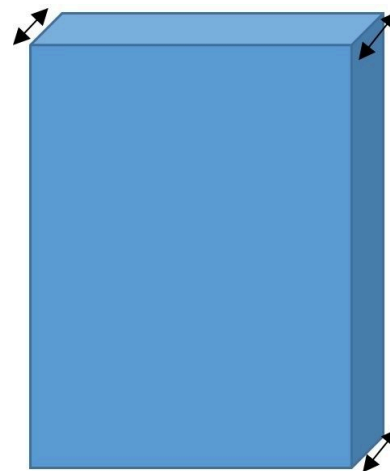

The overall appearance with color shade differences being present or not can be assessed in general only after a longer period of time (several weeks in some cases). The uniformity of color should be assessed from a typical viewing distance.

2 SAFETY

2.1 SAFETY PRECAUTIONS

Fireplaces may be set up only in rooms or areas with no risk of danger due to their location, structure or intended use.

Working on the stove	Installation, commissioning, servicing and maintenance works on the product may be carried out only by an authorized stove-fitter. Safety and efficiency of the system depend on this!
----------------------	--

Working with electronics	Switch off the emergency switch or circuit breaker, and secure them against switching on again.
--------------------------	---



Fireplaces with external air supply are not independent from room air supply and must be considered and designed as roomsealed fireplaces. In connection with a ventilation or extraction system, we recommend the use of a negative pressure safety device USA.



If additional parts are installed on the fireplace which are not approved for this appliance by Ulrich Brunner GmbH (for example, an external control unit), it is a customized product that meets customer requirements. The resulting fireplace insert is not type-tested; the declaration of performance of this fireplace insert will be no longer valid.

The CE mark must be removed from the heating insert!

The responsibility for installation (according to TROL) and operation lies exclusively with the specialist craftsman!

Installation must be carried out by an authorized stove-fitter, because safety and efficiency of the system depend mostly on proper installation of the product. All valid stove fitting rules and regulations of building law must be observed and followed. Make sure to instruct the owner or user about the functions and controls of the system and possibly installed safety devices.

Fireplaces must be built to ensure safe operation and fire safety in order to eliminate possible risks and unacceptable loads. They have to be ready for use over an adequate period of time.

Make sure to instruct the owner or user about the functions and controls of the system and possibly installed safety devices.

Remember to use only genuine replacement parts.

Stoves with water boilers are ready for use only with a fully functional boiler section.

2.2 HEAT RADIATION RANGE

Within the range of heat radiation through the fireplace door (glass pane) there must be a minimal distance to all flammable parts (e.g. built-in furniture, fixtures) of at least 80 cm.

Outside the heat radiation range, any flammable fixtures cannot be exposed to temperatures above 85°C. Large-dimensioned parts from flammable materials or built-in furniture must have a clearance of at least 5 cm to external fireplace cladding. In this clearance, the room air must be able to circulate without any obstacles.

In general, parts of external fireplace cladding are allowed to be installed without any clearances, if such parts are not exposed to temperatures above 85°C under any circumstances.

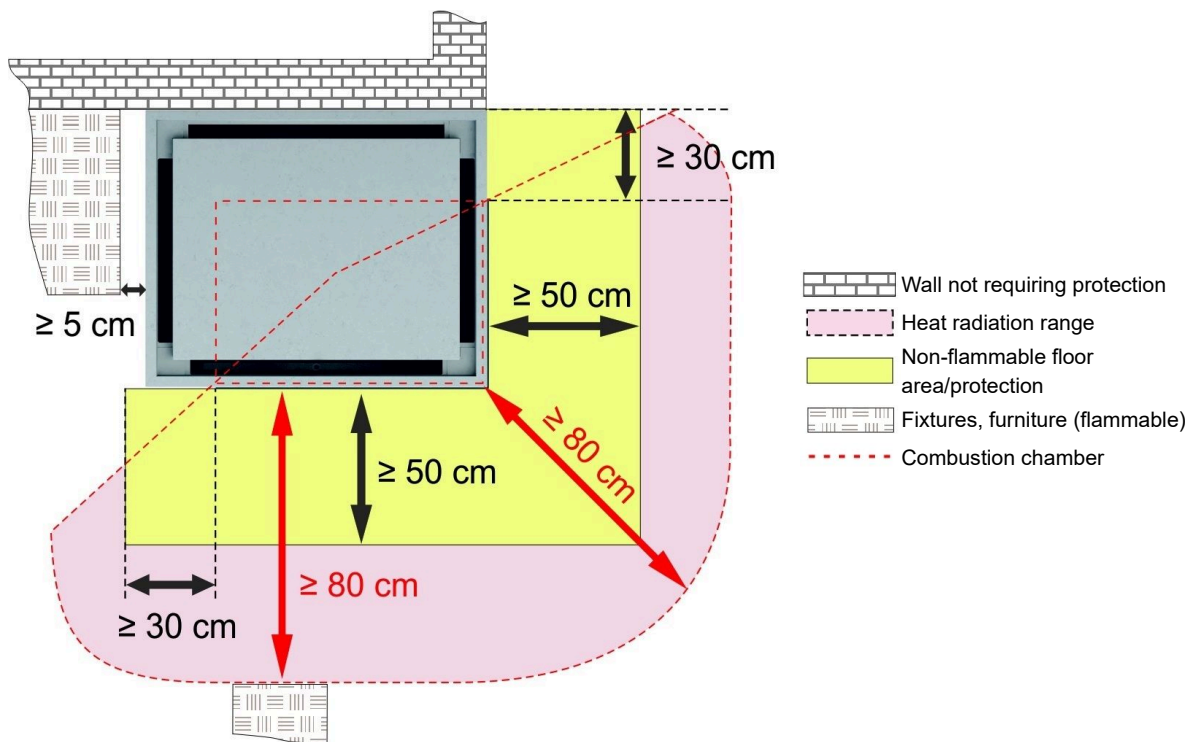

2.3 MINIMAL DISTANCES

Minimal distances to adjacent walls

Depending on wall type (flammable or non-flammable wall), the minimal distances are different. With installed heat protection screen it is possible to minimize the distance to adjacent wall.

Without heat protection screen:

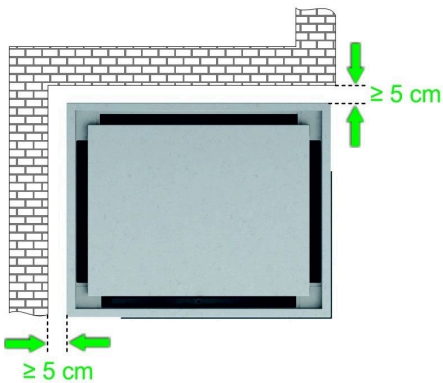

With installed heat protection screens:

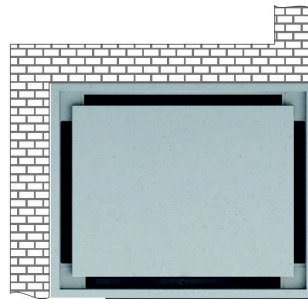

Other walls:

- ▶ aerated concrete
- ▶ ceramic bricks
- ▶ sand-lime bricks
- ▶ mineral building materials with wall thicknesses > 10 cm

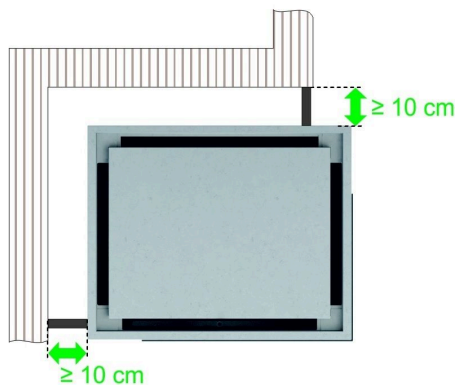

Walls requiring protection:

- ▶ flammable walls and wall structures
- ▶ load-bearing reinforced concrete walls
- ▶ other walls up to 10 cm thickness
- ▶ walls with built-in furniture behind them (heat accumulation)

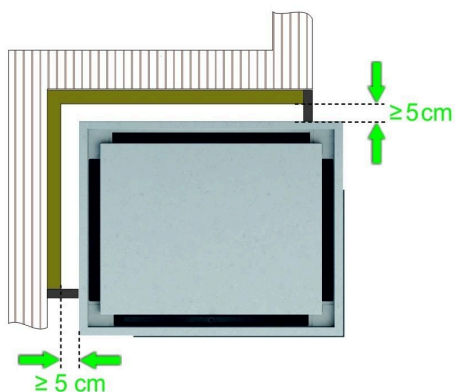
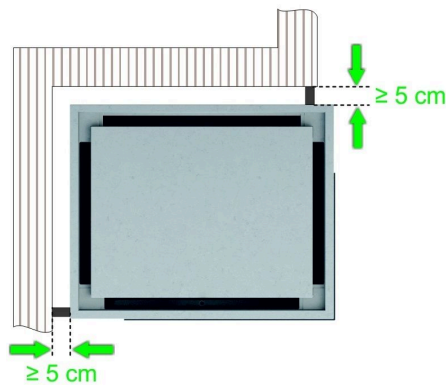

Walls requiring protection with 10 cm brick lining or alternative insulation

Thermal concrete slabs (assembled by craftsman, with exposed joints)



Non-flammable wall, not requiring protection (other walls)



Flammable walls requiring protection



Brick lining or equivalent alternative insulation material, insulating panel

3 INSTALLATION

3.1 SETTING UP



CAUTION

Risk of injury due to heavy loads

Moving the heating element and heavy cladding parts can cause crushing injuries.

- ▶ Ensure a secure hold when carrying the individual parts.
- ▶ Ensure correct use when using the assembly tools supplied.
- ▶ Move the heating element and cladding parts with at least two people.

3.1.1 BASE PLATE

3.1.1.1 COMPONENTS BASE PLATE

Base plate (BKO1000-219)

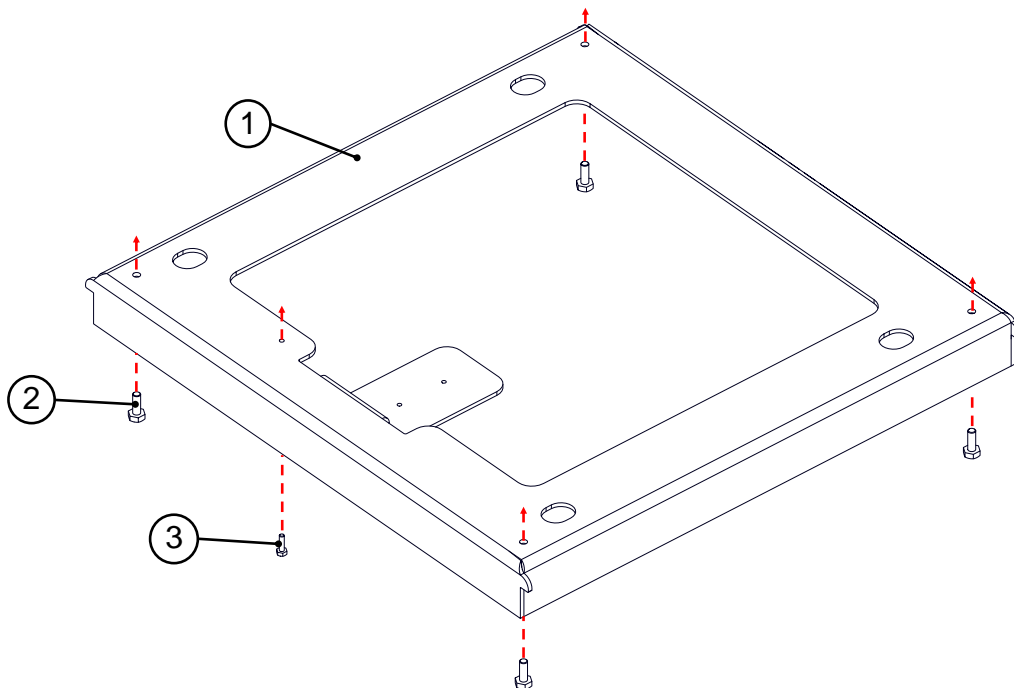

Position	Designation	Item no.	Pcs.
1	Base plate		1
2	Hexagon head screw M8x20	00634	4
3	Hexagon head screw M5x16	800299	1

3.1.1.2 SET UP THE FIREPLACE

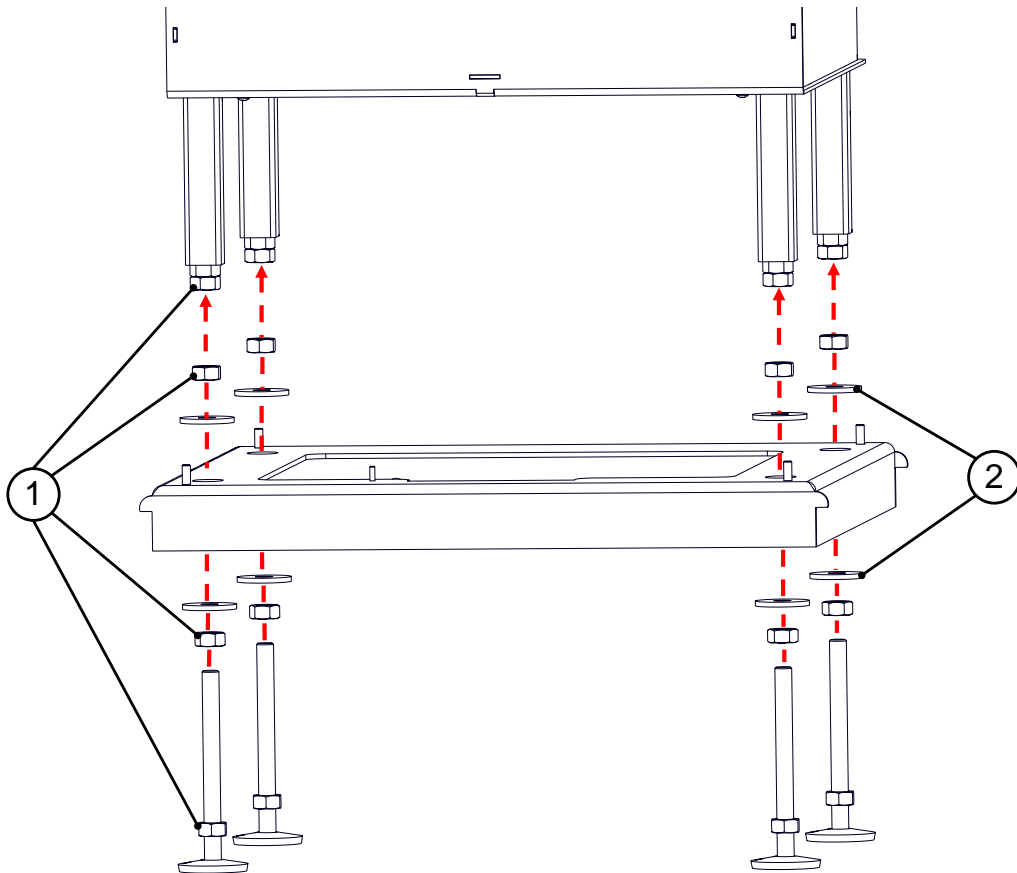

Position	Designation	Art.-Nr.	Pcs.
1	hexagon nut M14	800136	16
2	Clamping disk	BKO1000-249	8

3.1.2 ADJUSTMENT

Adjusting the adjustable feet

- ▶ The weight of the stove construction is borne by the adjustable feet, not by the base plate!
- ▶ Distance between the lower edge of the base unit and the underside of the adjustable feet is approx. 2-3 mm

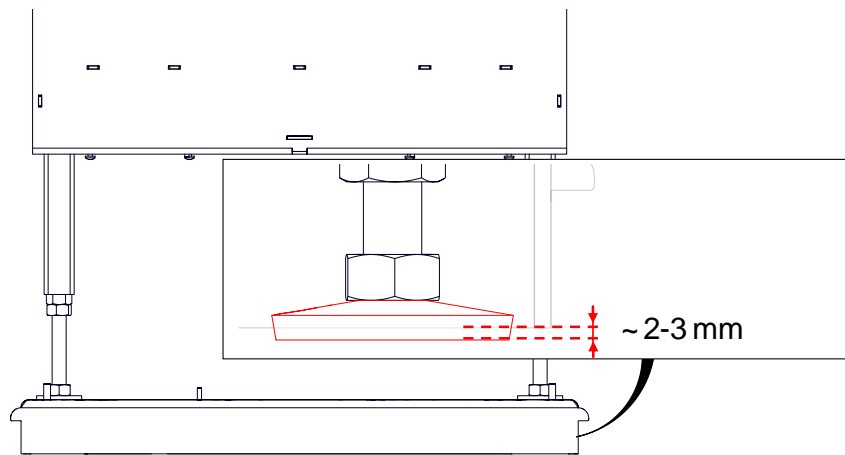

Adjusting the stove

- ▶ Align the base unit with a level indicator.

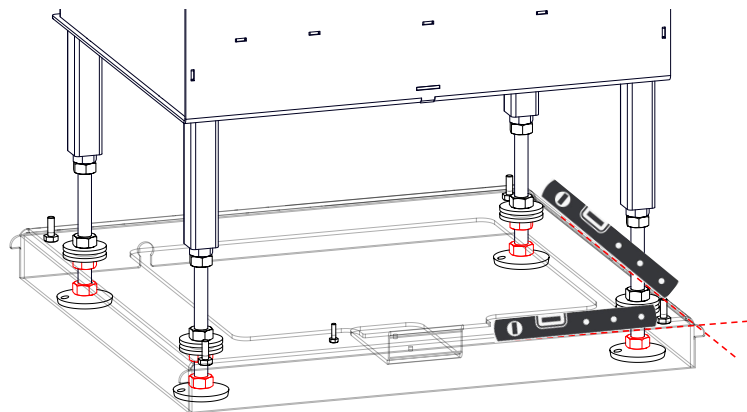

- ▶ Adjust height with nuts.

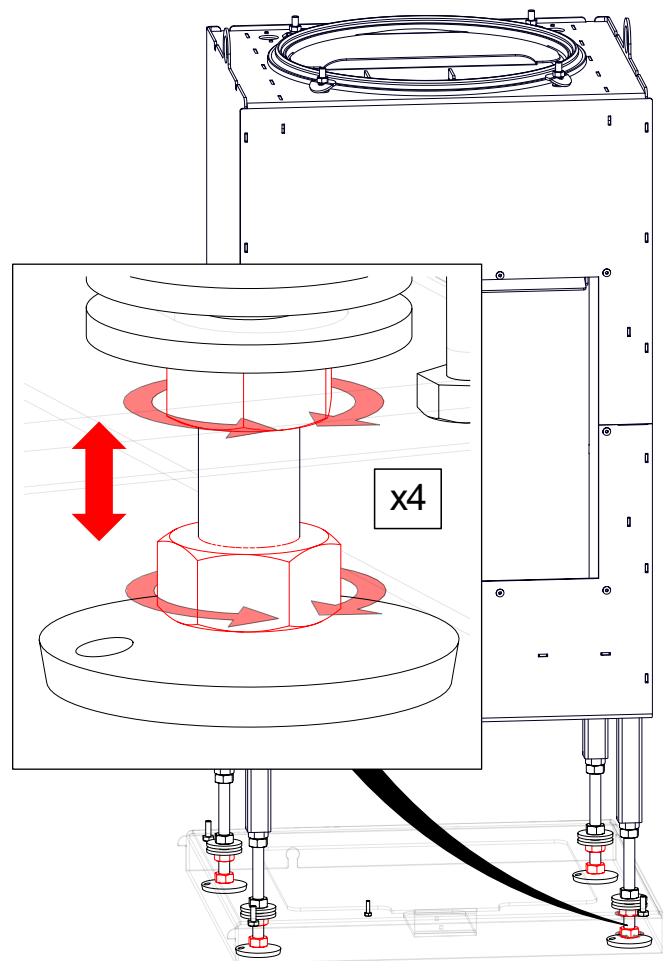

- ▶ Distance between floor unit and lower edge of door recess front: 431 mm

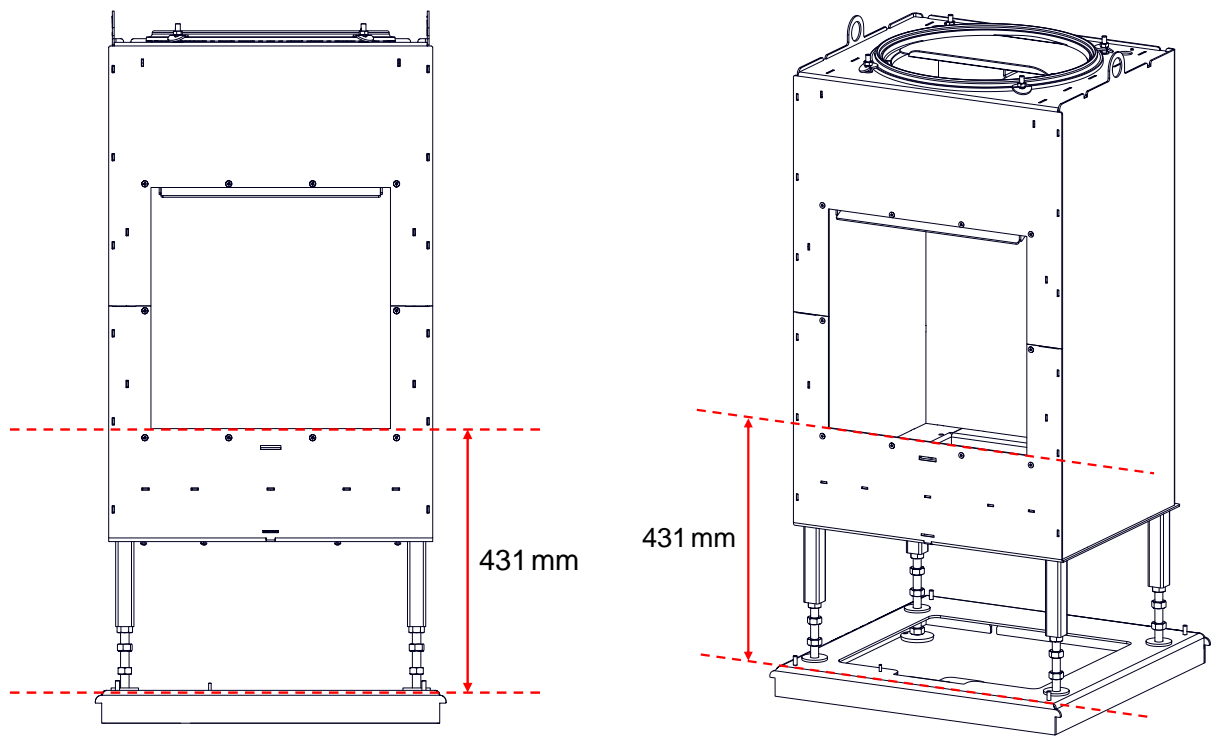

► Adjust height with nuts.

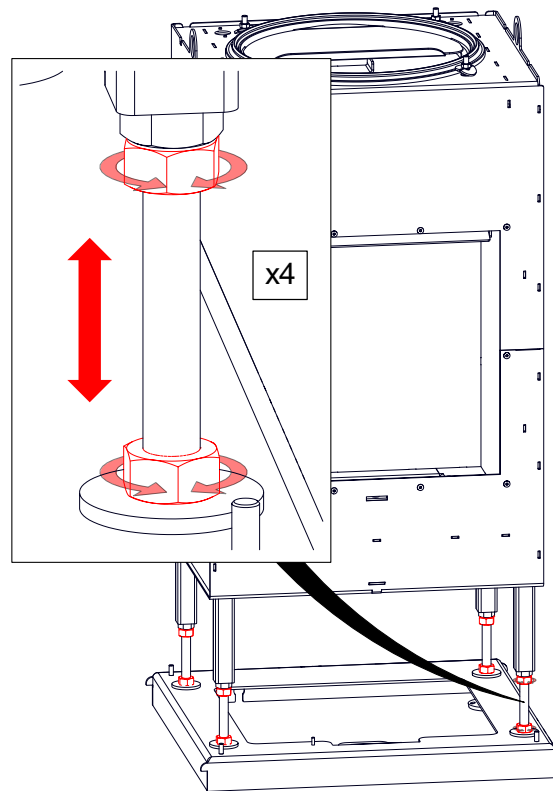

► Align the corpus with a level indicator.

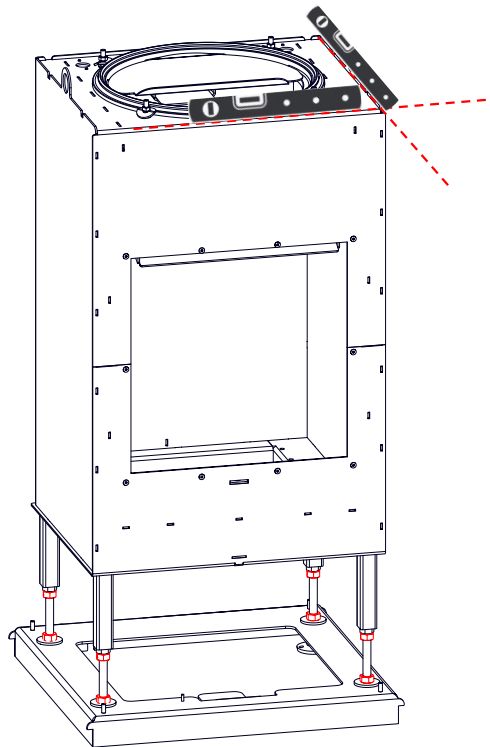

3.2 CLADDING FRAME

3.2.1 COMPONENTS CLADDING FRAME

Cladding frame BKO 42-42 (BKO1000-280)

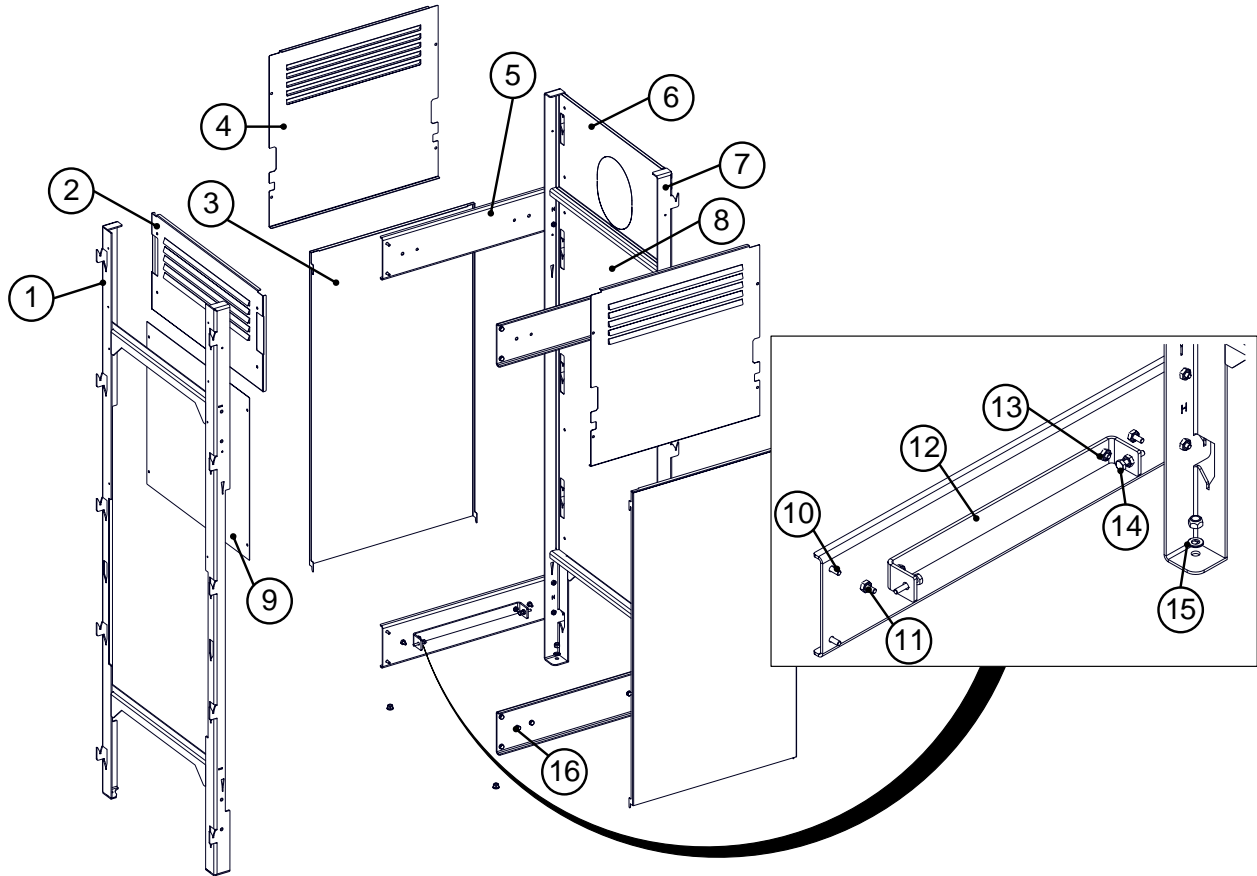

Position	Designation	Item no.	Pcs.
1	Front carrier	BKO1000-215	1
2	Front heat protection plate		4
3	Heat protection plate bottom right-left	BKO1000-241	2
4	Heat shield right-left	BKO1000-232	2
5	Beam reinforcement	BKO1000-214	2
6	Top heat protection plate		1
7	Rear carrier	BKO1000-231	1
8	Lower heat protection plate		1
9	Top front heat shield	BKO1000-243	1
10	Hexagon head screw M6x16	800201	20
11	Hexagon head screw M6x25	800275	4
12	Alignment bracket	BKO1000-224	2
13	Hexagon welding nut	800363	8

Position	Designation	Item no.	Pcs.
14	Hexagon head screw M6x30	800665	4
15	Hexagon nut with clamping part	800157	4
16	Washer	00628	20

3.2.2 INSTALLING CLADDING FRAME

Work steps

Follow the steps for installing the heat exchanger variants before the cladding frame is fully installed together with the heat protection plates.

1. installation of cladding support

Front cladding support with recess for door.

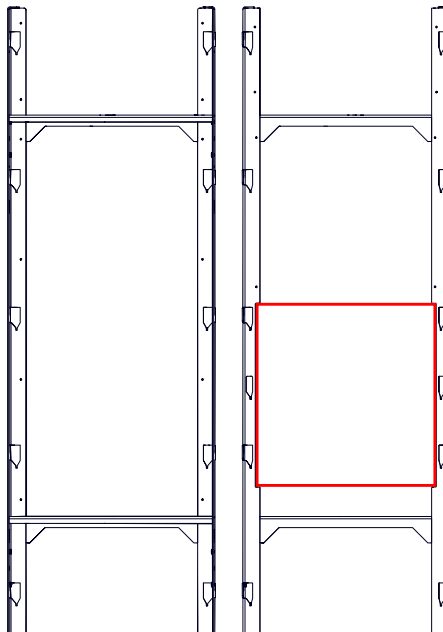

- Fit rear cladding support with 2x hexagon head screw M8x20.

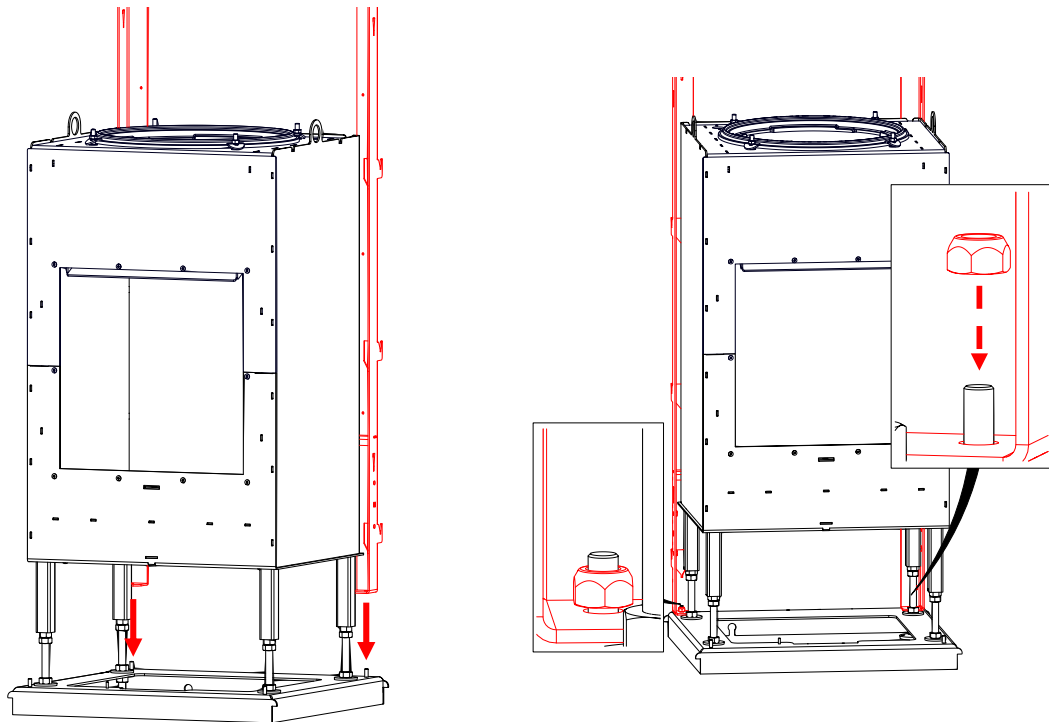

- Mount the front fairing carrier with 2x hexagon head screw M8x20.

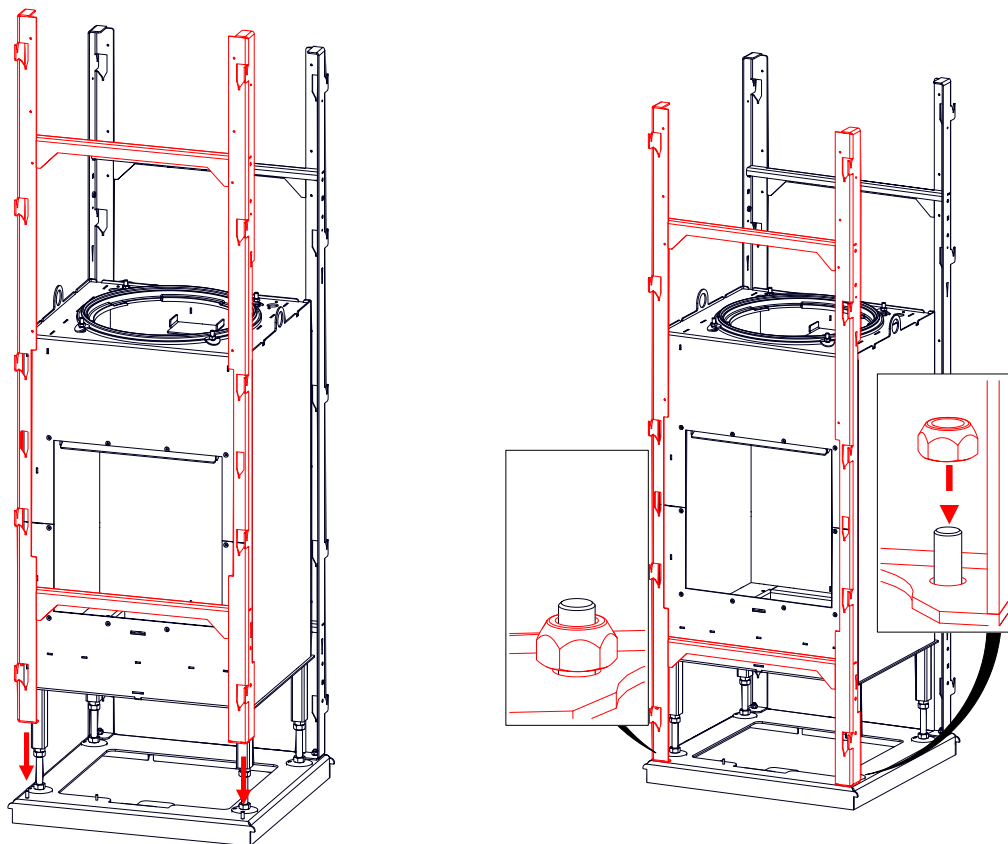

- Mount the upper stiffeners of the carrier with 4x hexagon head screw M6x16 each.

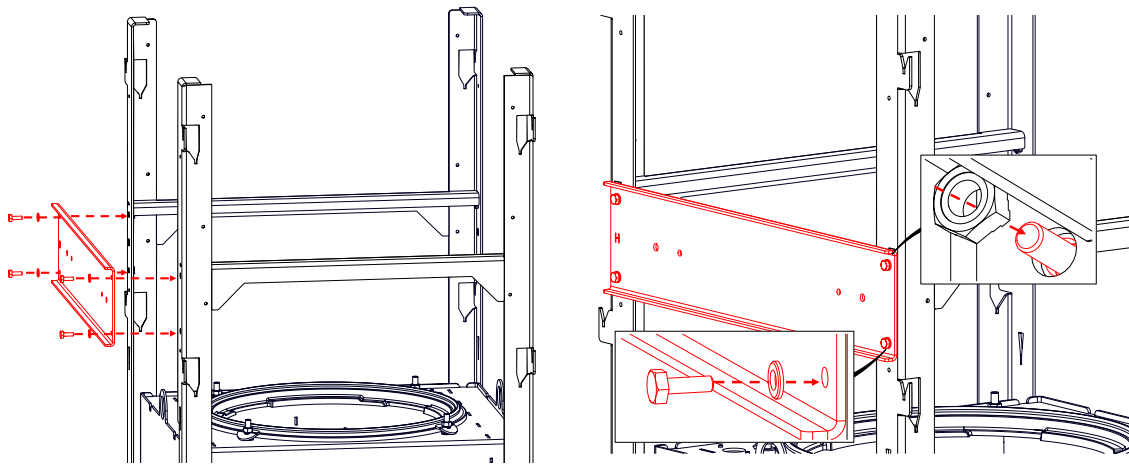

Assembly on both sides.

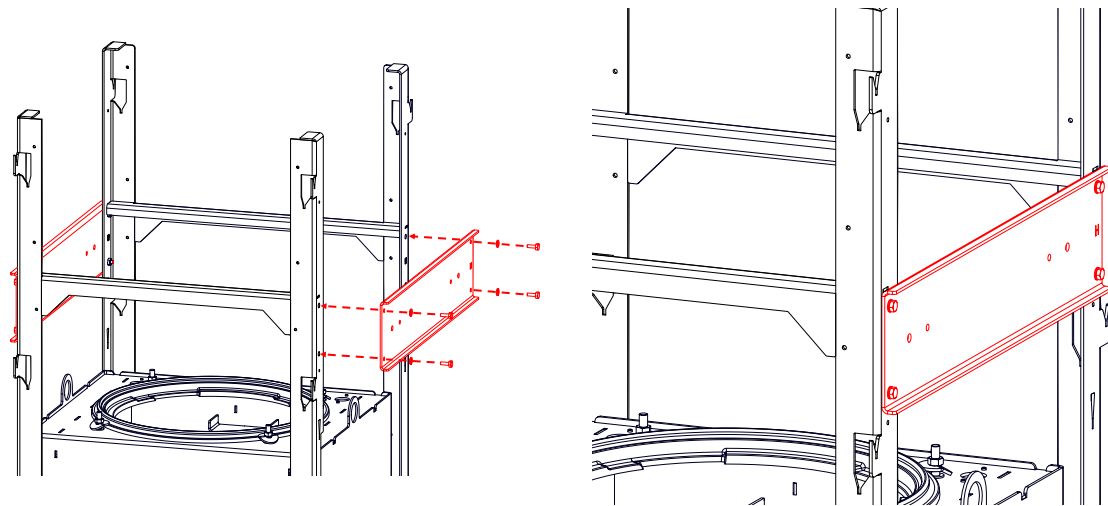

2. mounting alignment brackets

The heating insert can be adjusted in its position relative to the cladding frame using the alignment brackets and the handle screws on both sides.

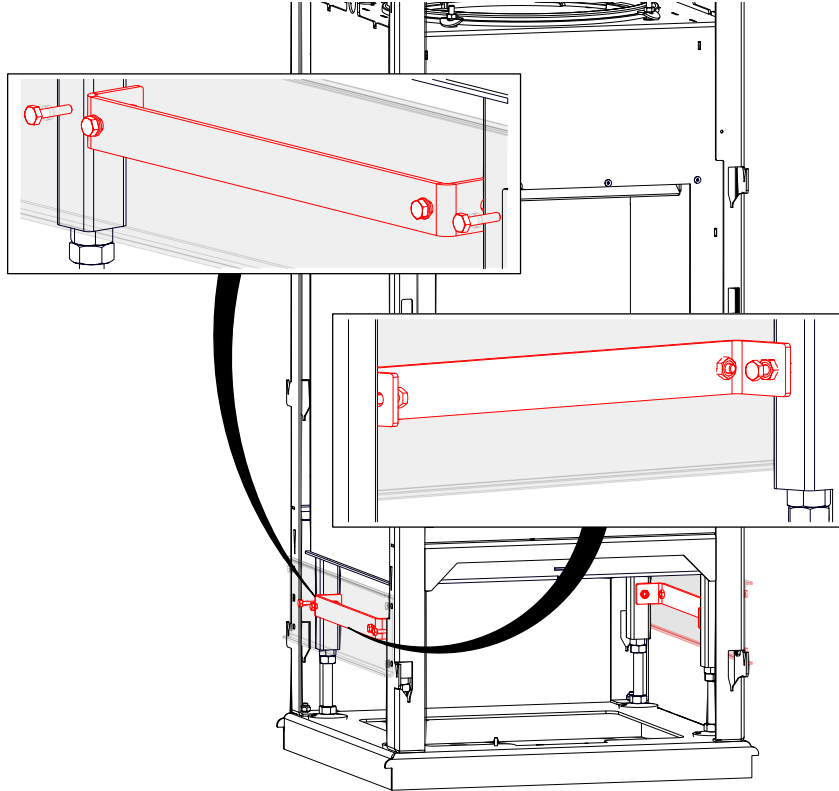

- Mount the alignment bracket on the inside of the lower reinforcement support with 2x hexagon head screw M6x16.

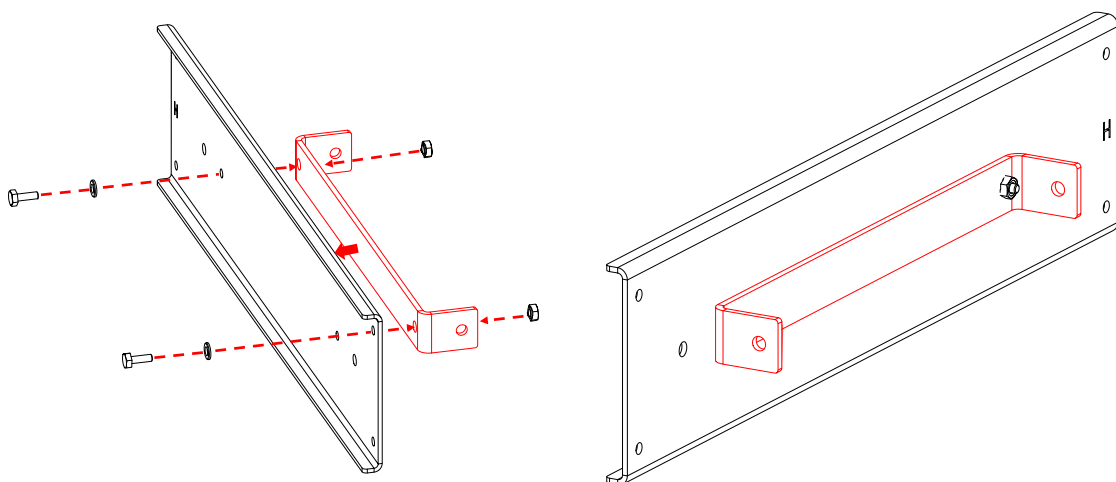

Fit the alignment brackets to both lower stiffeners.

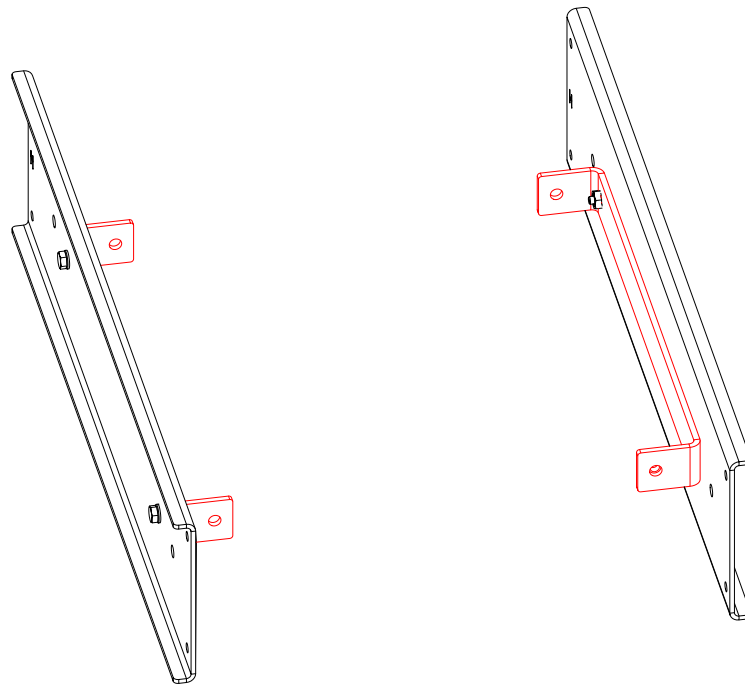

- ▶ Attach 2x M6x25 jack bolts to the outside of the lower stiffeners.

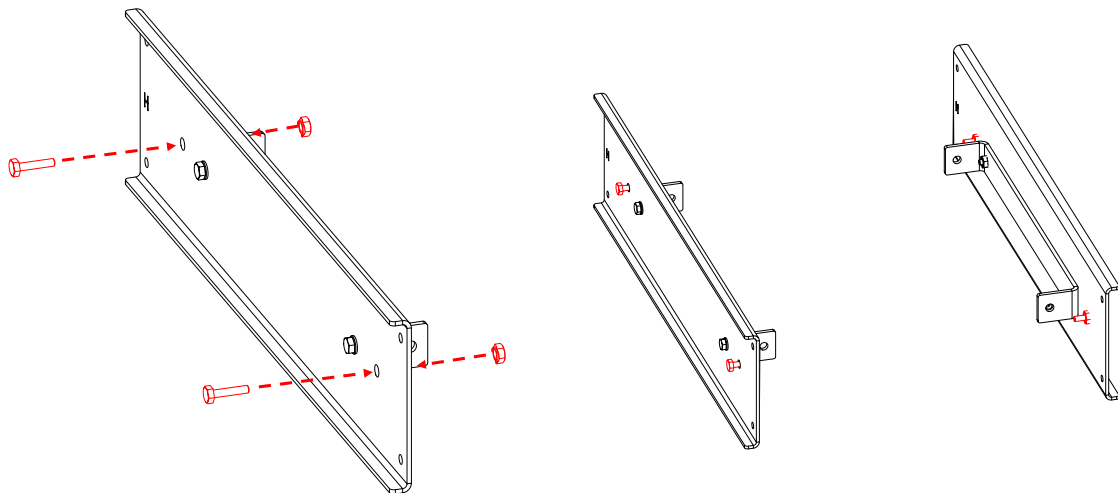

- ▶ Mount the lower stiffeners support with 4x hexagon head screw M6x16 each.

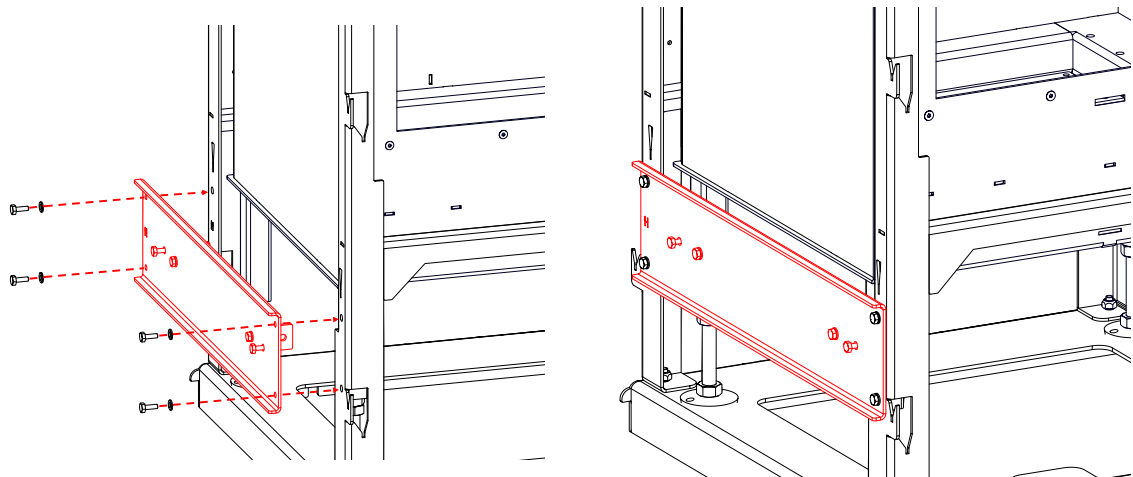

► Assembly on both sides.

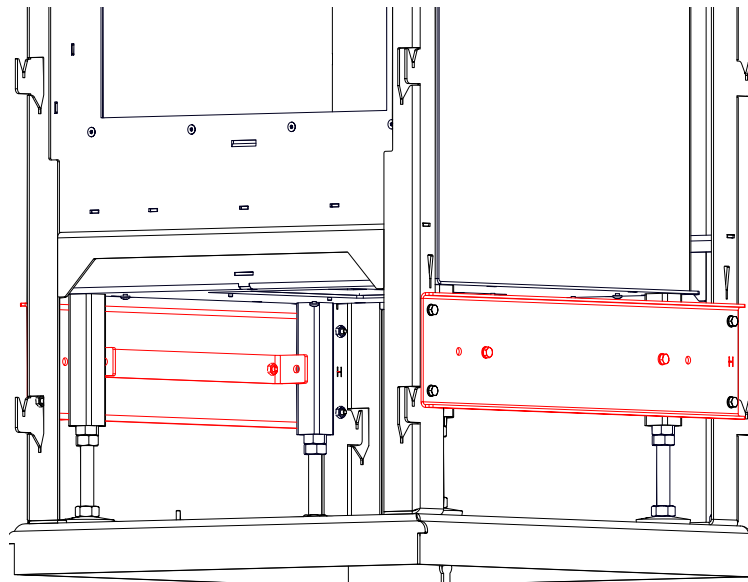

► Attach 2x M6x30 handle screws to the inside of the alignment brackets on both sides.

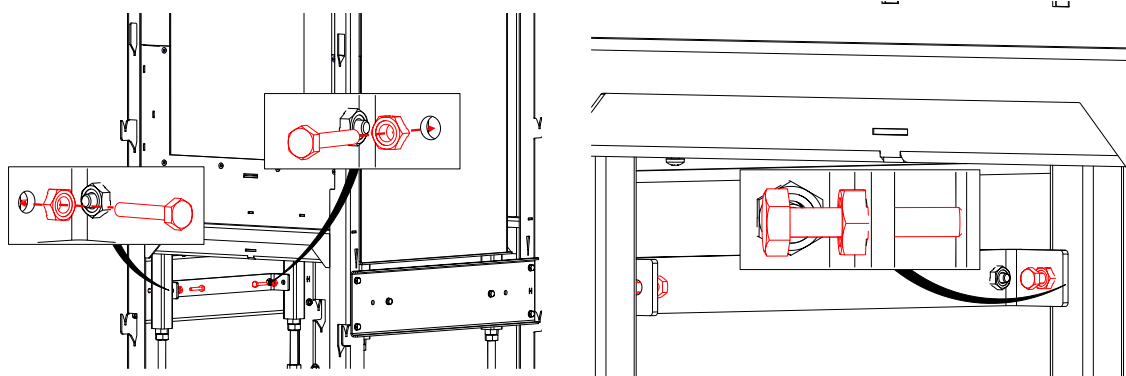

3. adjust the heating insert to the cladding frame

- ▶ Adjust the handle screws for alignment to the front cladding frame.

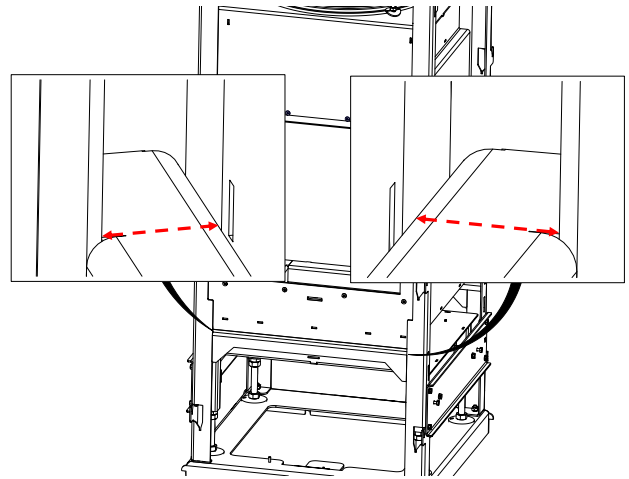
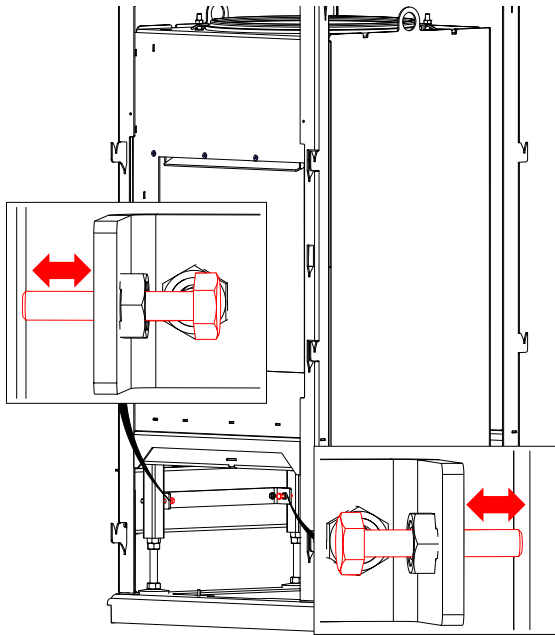

- ▶ Adjust the handle screws for alignment to the side of the cladding frame.

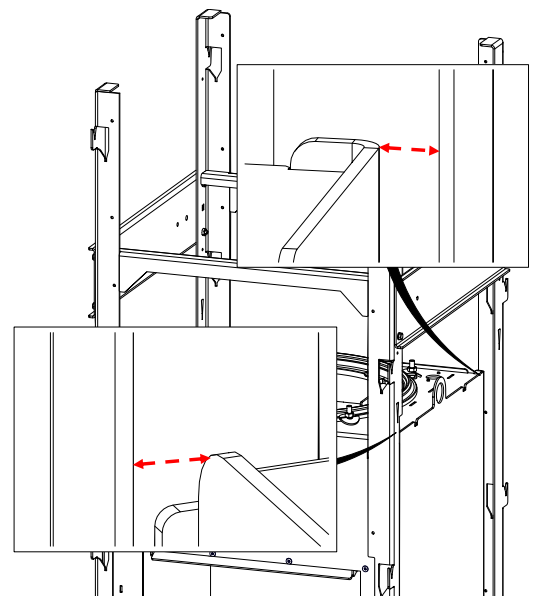
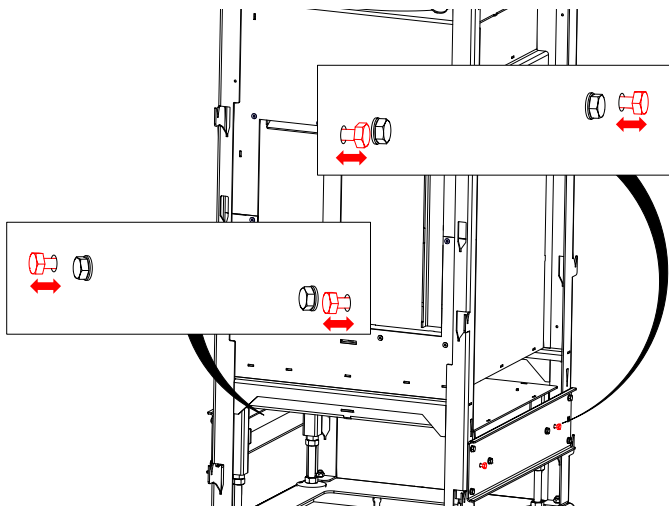

4. fit heat protection plates

- Fit rear heat protection plate with 8x pan-head flange screw M5x6.

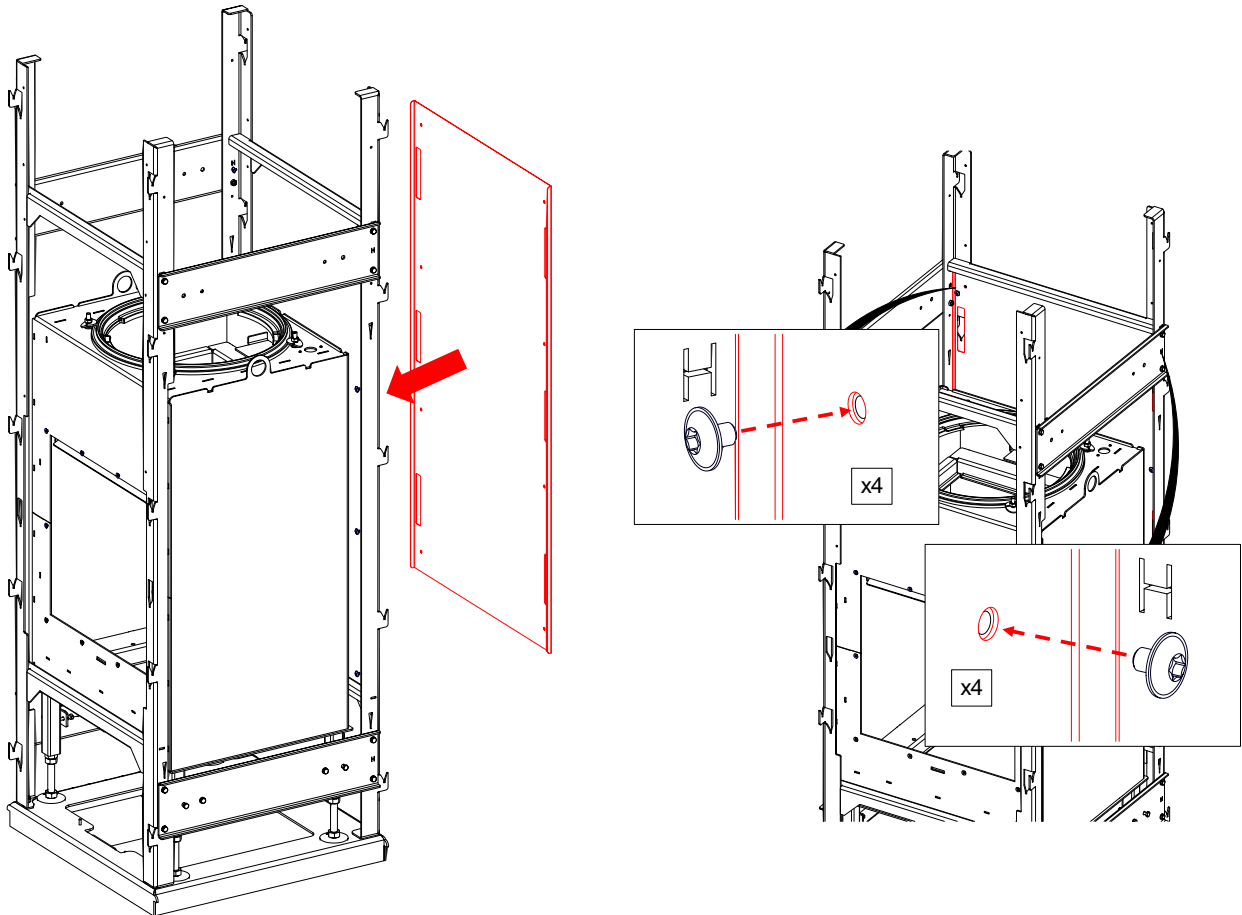

- Fit rear heat protection plate with 4x pan-head flange screw M5x6.

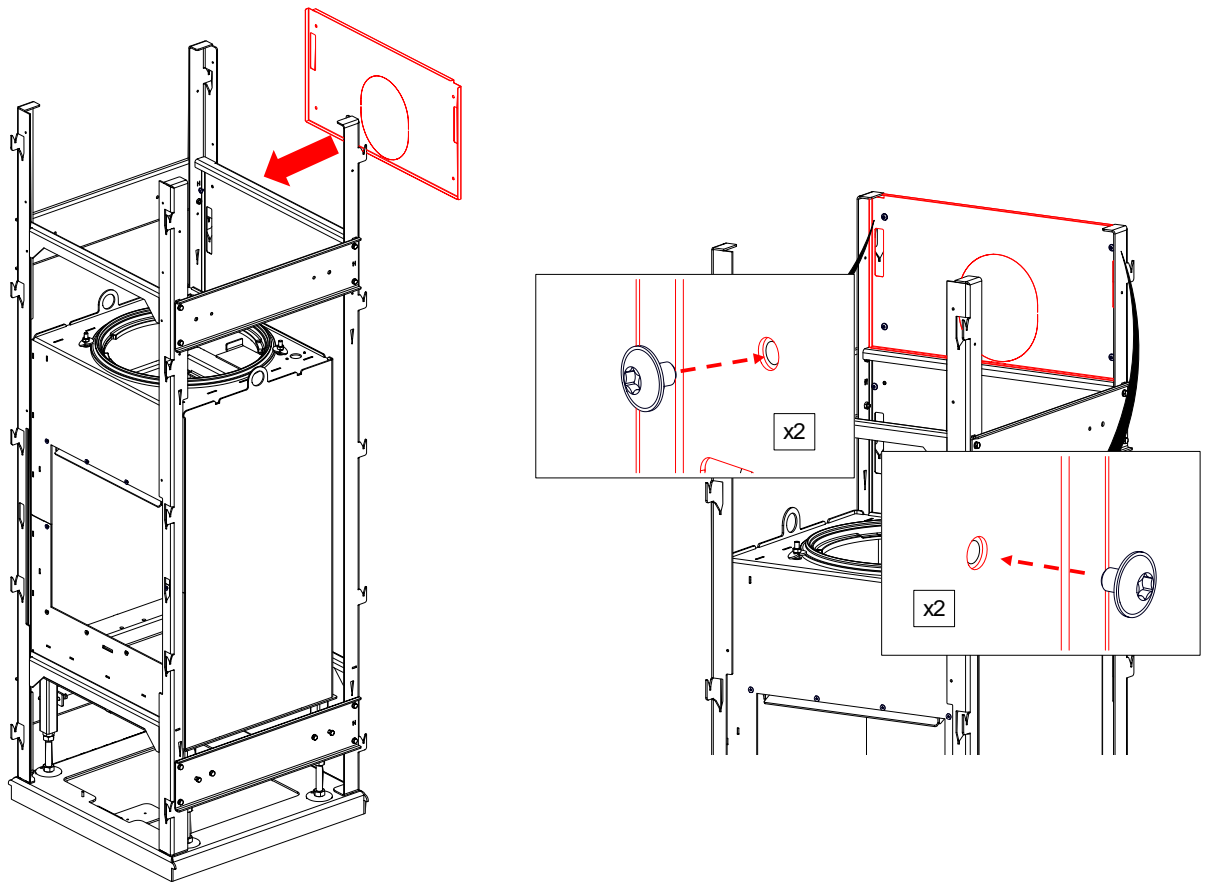

- ▶ Hook in the heat protection plate at the side.

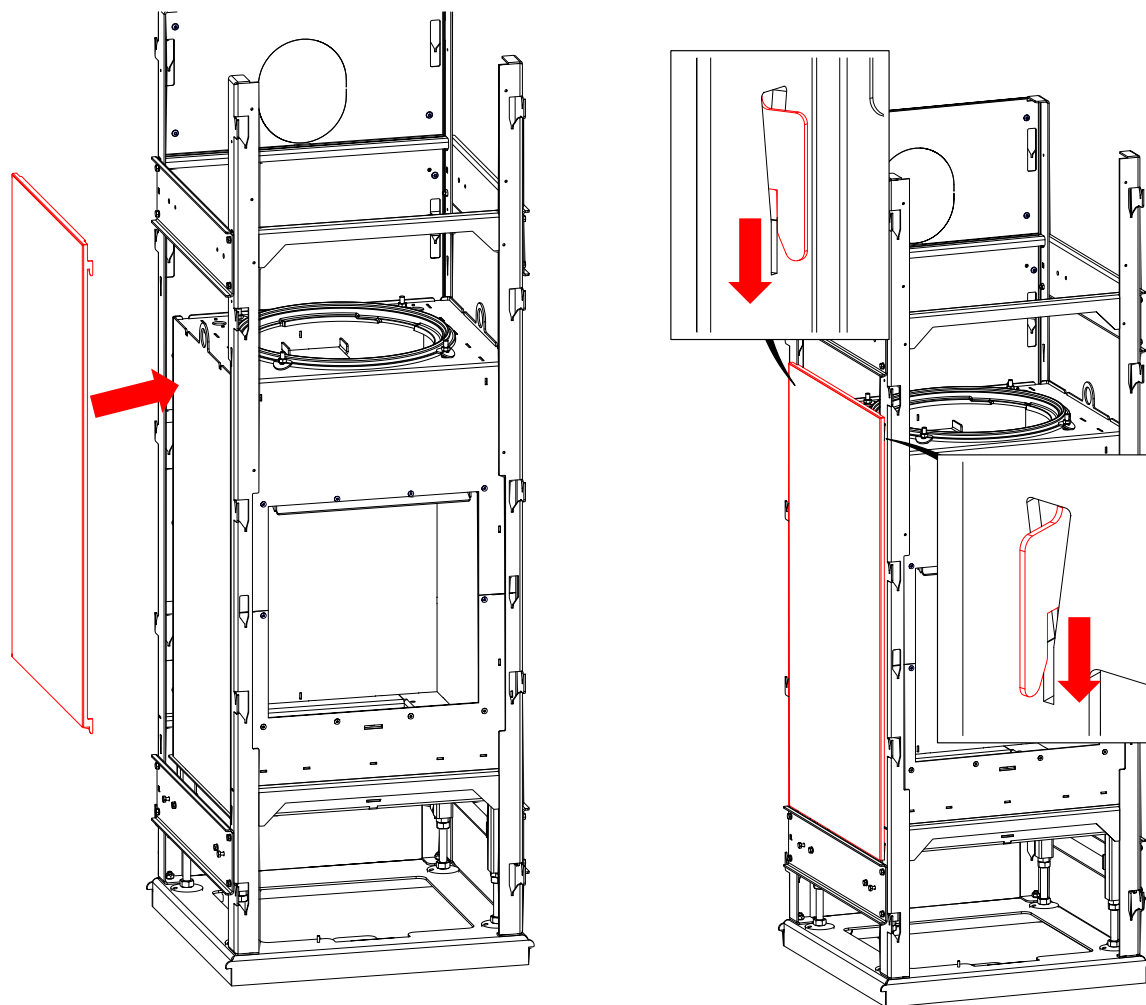

- Fit the heat protection plate at the side with 4x pan-head flange screw M5x6.

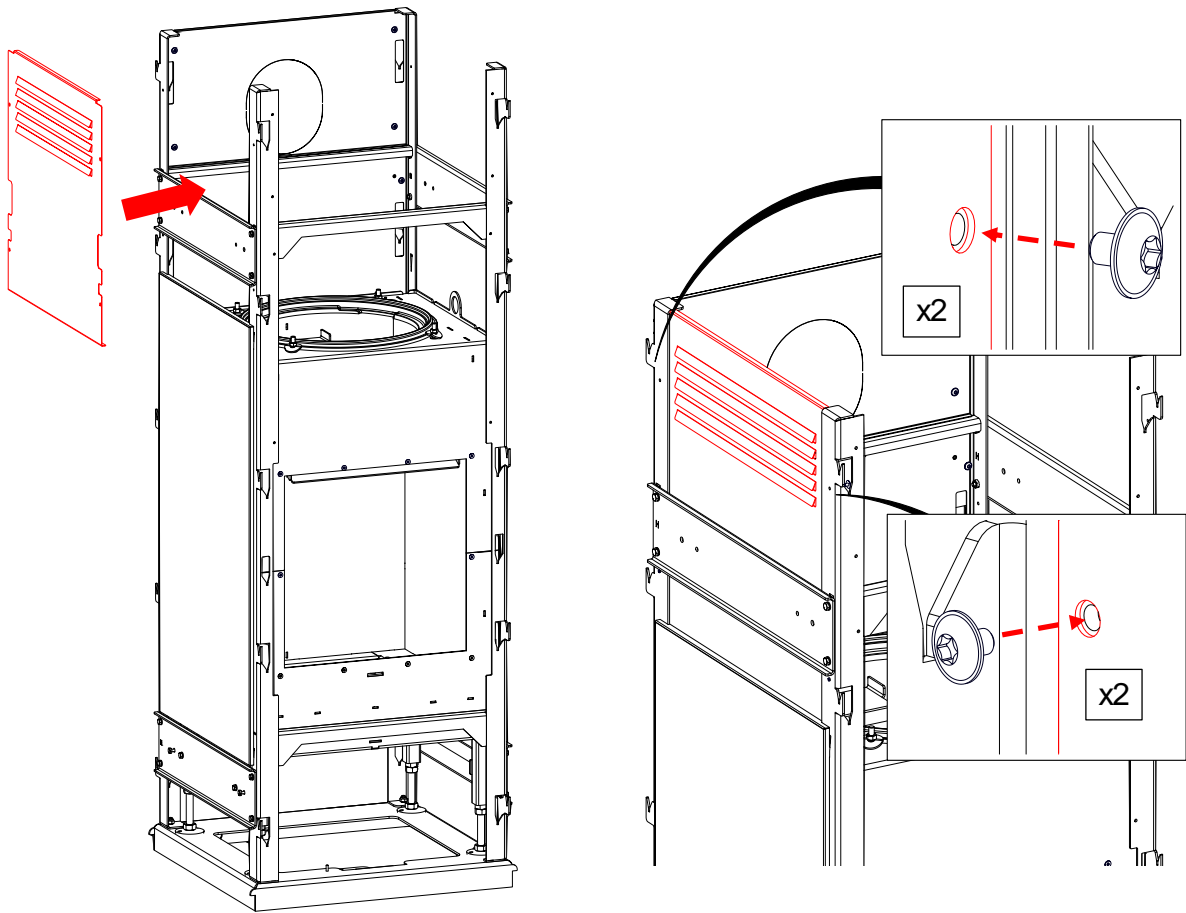

► Fit on both sides.

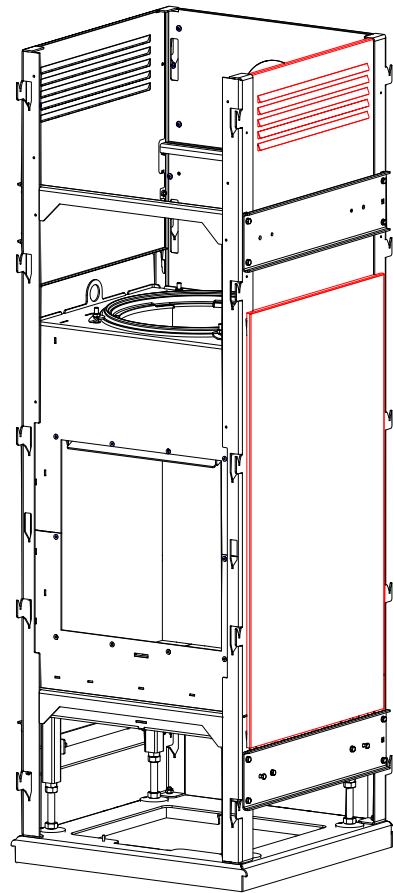
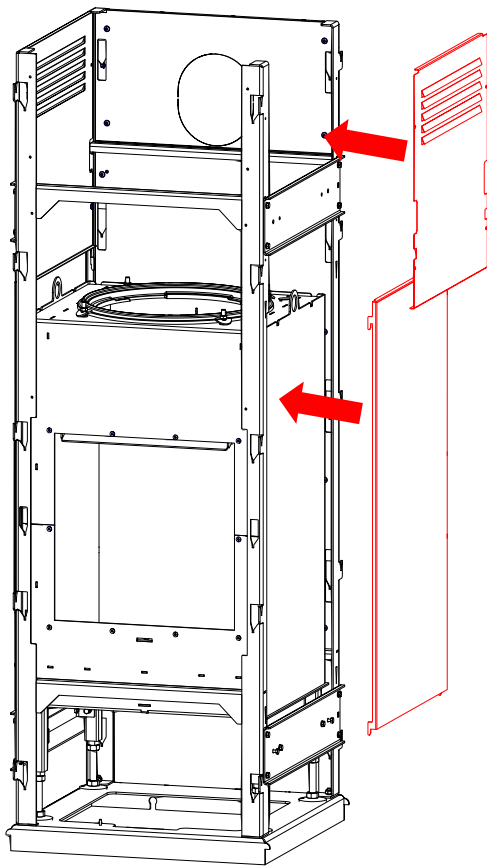

- Fit the heat protection plate at the front with 4x pan-head flange screw M5x6.

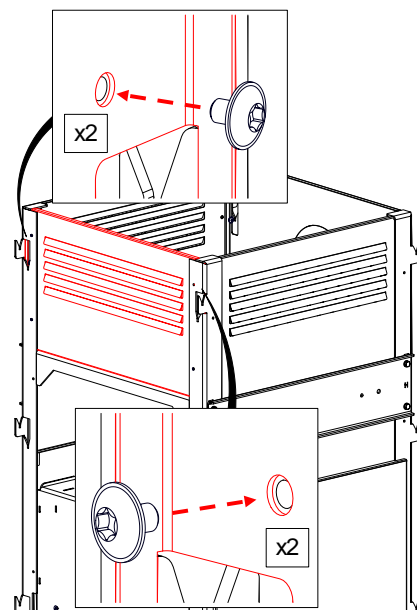
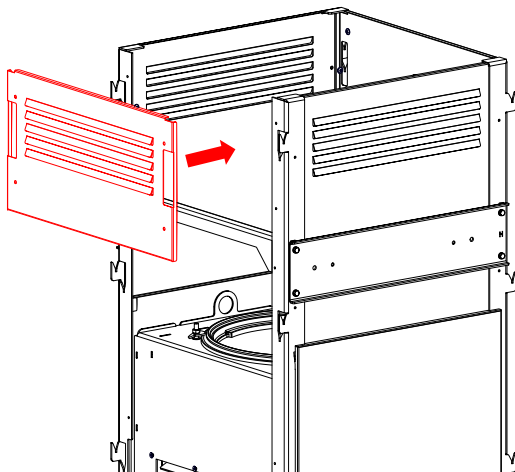

- Fit the heat protection plate at the front with 4x pan-head flange screw M5x6.

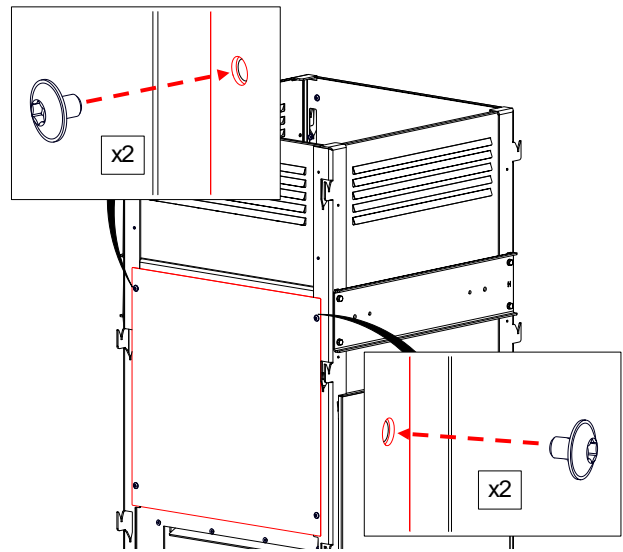
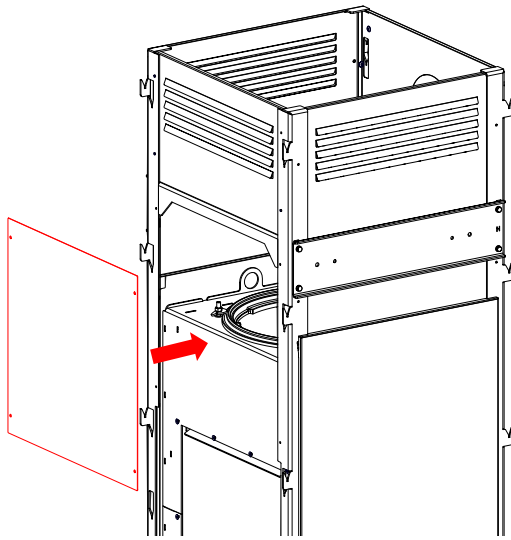

3.3 CLADDING

3.3.1 COMPONENTS OF CLADDING

Cladding BKO 42-42 (BKO1000-290)

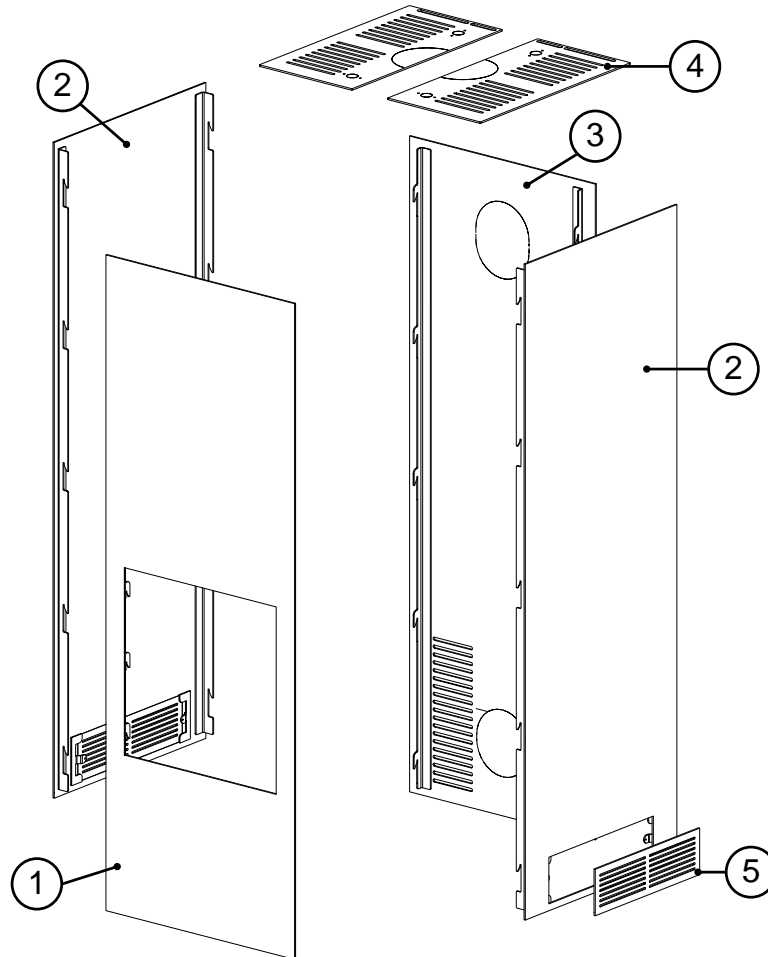

Position	Designation	Item no.	Pcs.
1	Front cladding	BKO1000-203	1
2	Side panel cladding	BKO1000-210	2
3	Rear panel cladding	BKO1000-208	1
4	Cover	BKO1000-202	2
5	Side panel insert	BKO1000-213	2

3.3.2 INSTALLING OF CLADDING PANNELS

Work steps

**Risk of crushing due to heavy cladding panels**

Install the cladding with at least two people. Ensure a secure hold.

Fitting the cladding panels

- ▶ When attaching the cladding panels, make sure that they snap into place properly.

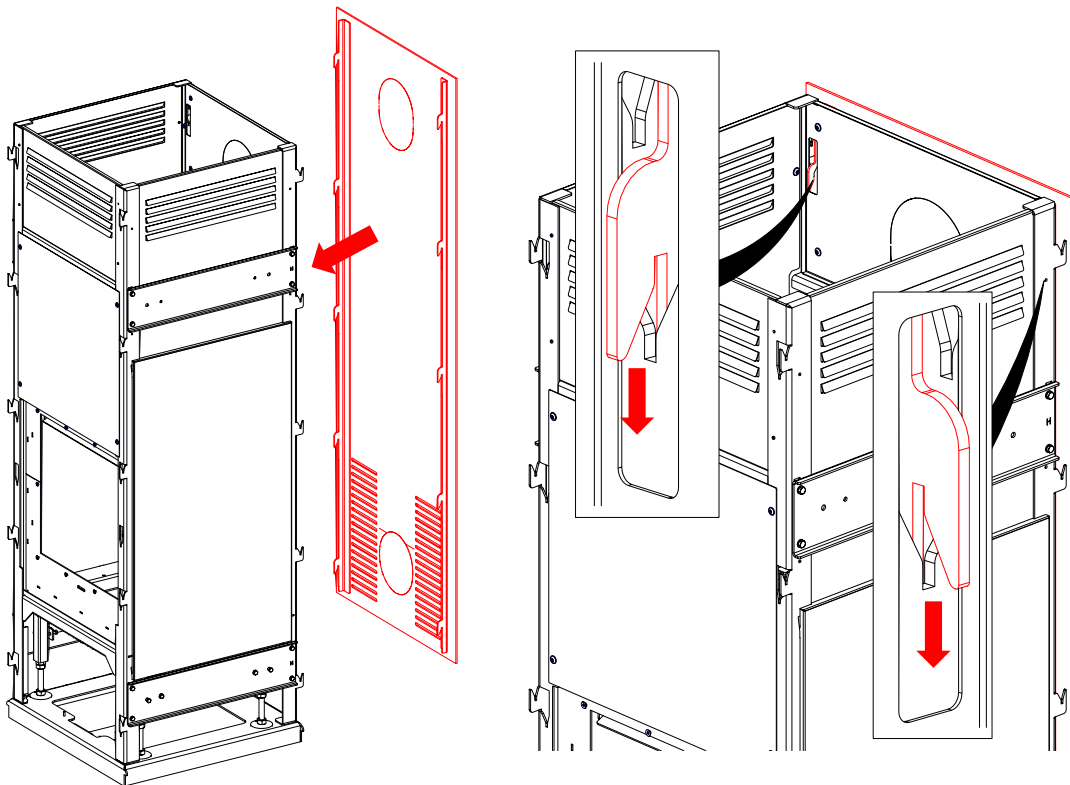
Rear cladding

Side cladding

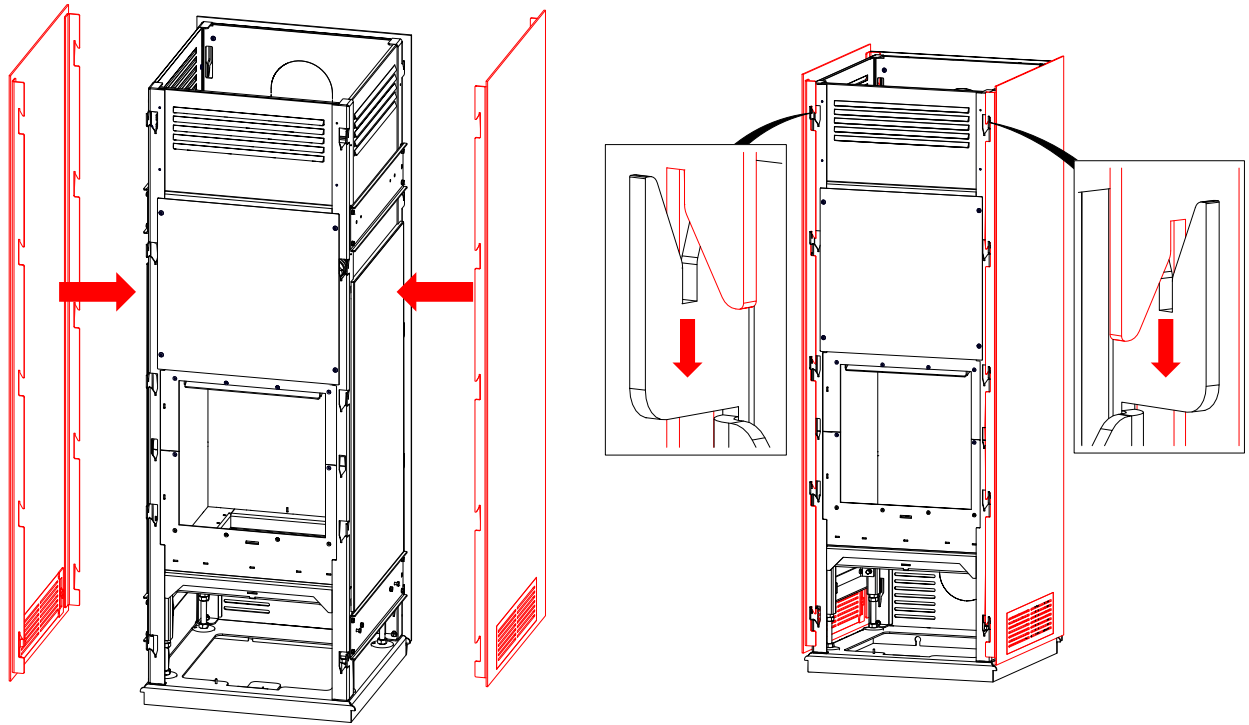

Front cladding

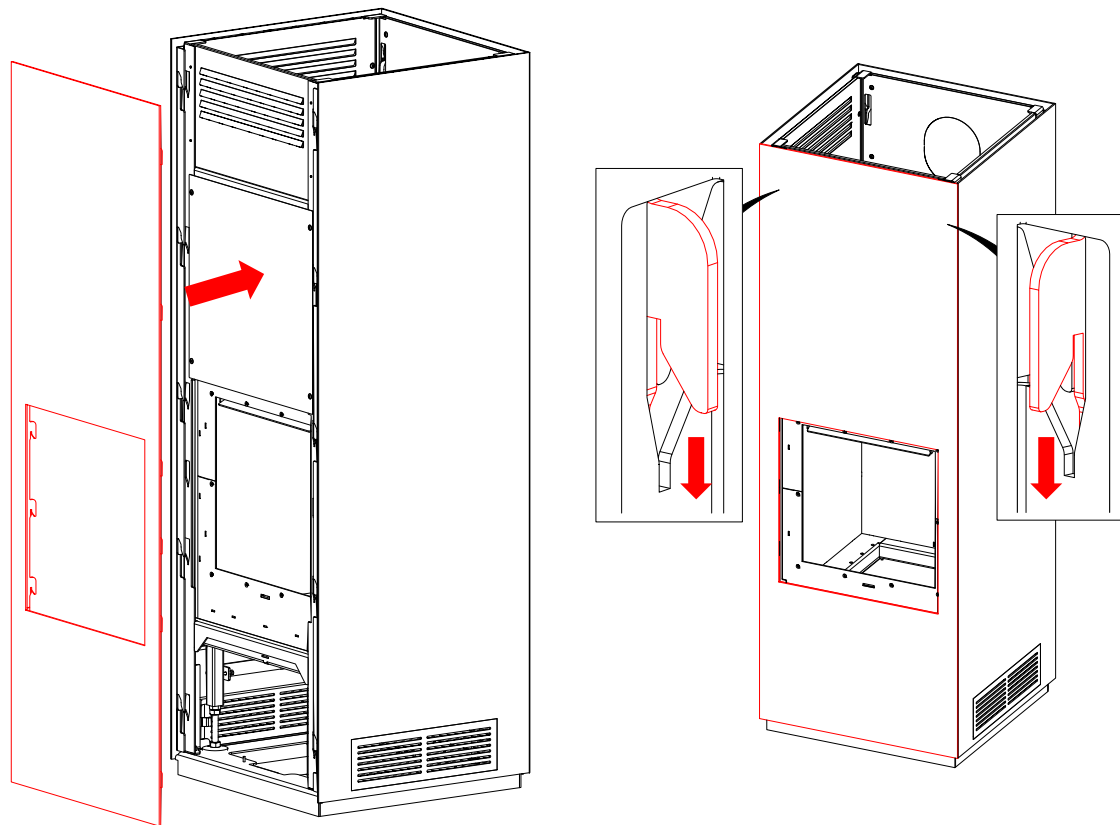

Fit the cover

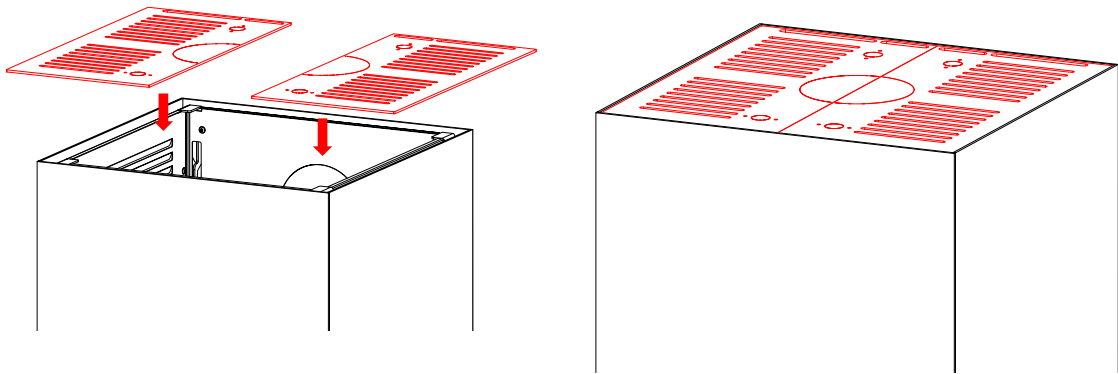

3.4 SIDE-OPENING DOOR

Fitting the door

- ▶ Mount the front of the heating insert with 10x countersunk screw M6x12.

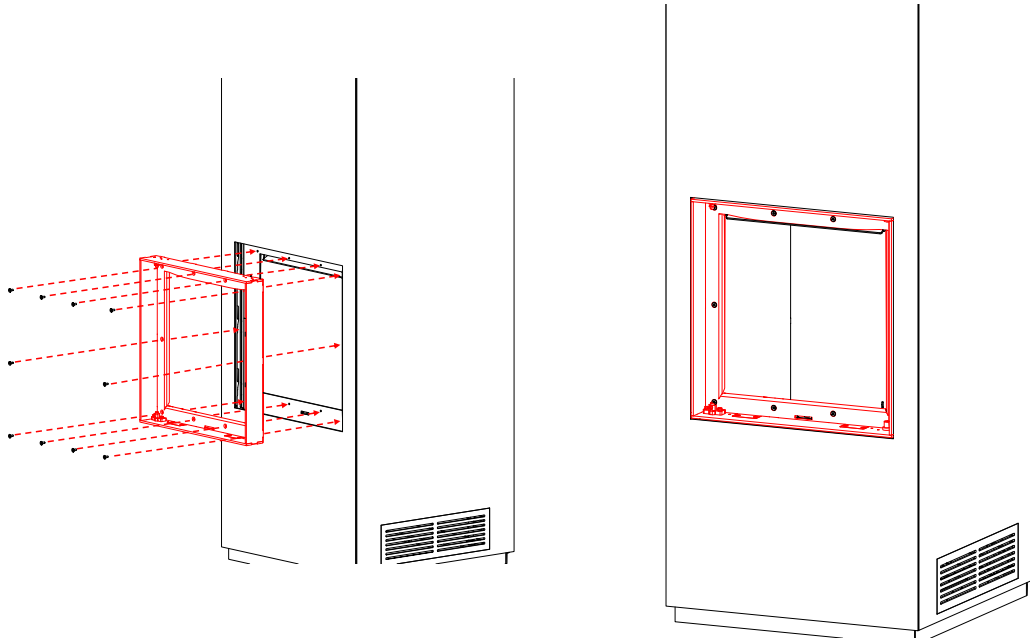

- ▶ Hang in the side-opening door.

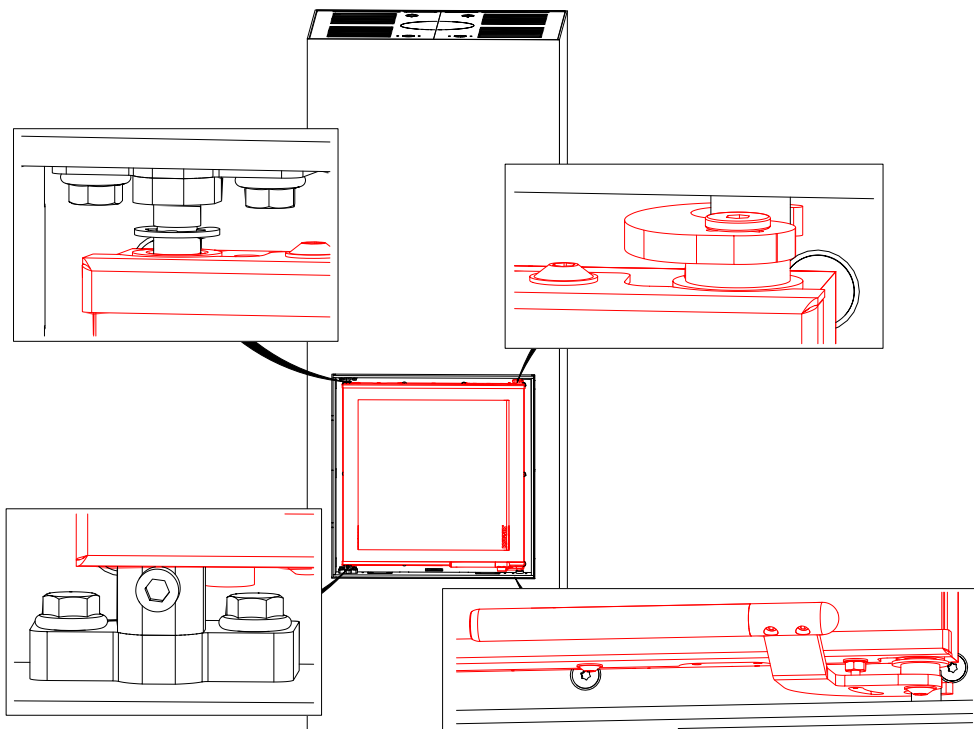

3.5 DEFLECTION

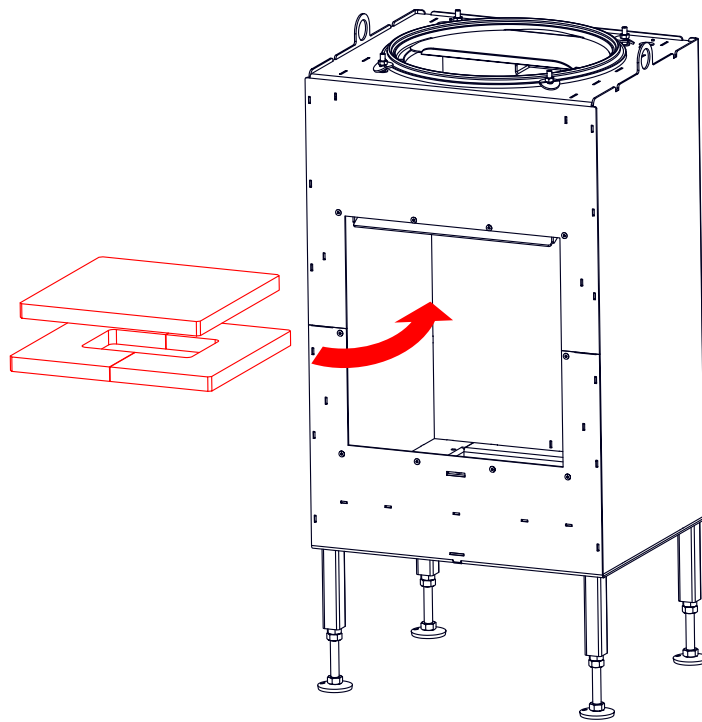

Workflow

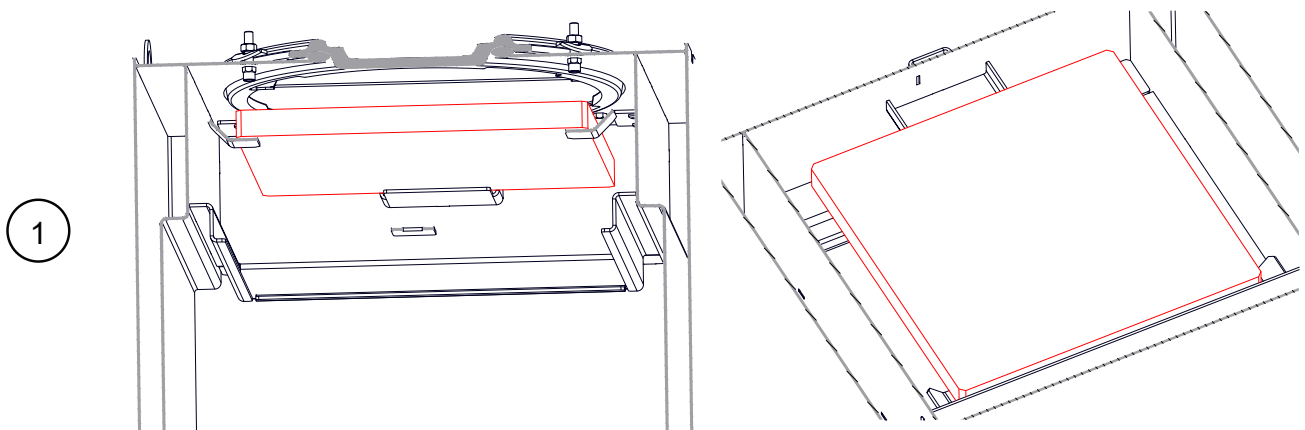

2

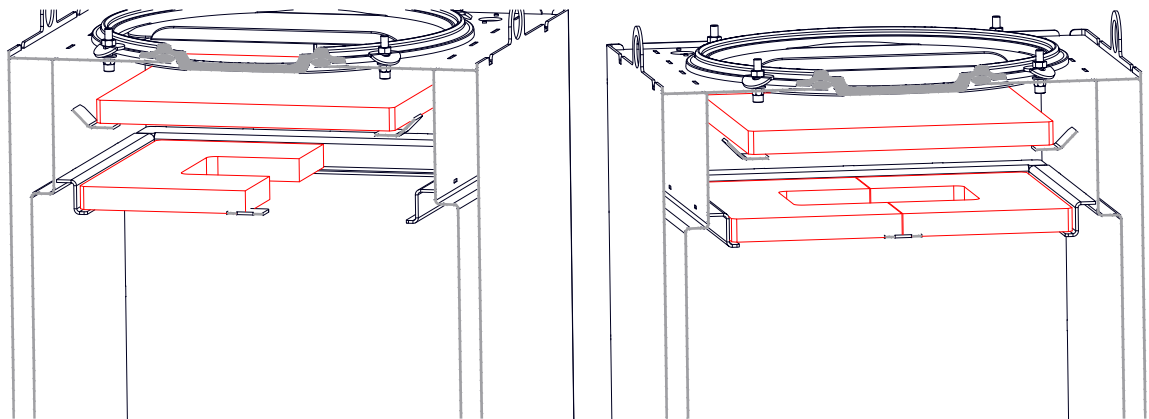

3.6 VARIANTS COMBUSTION CHAMBER LINING

3.6.1 CHAMOTTE INNER LINING

flat 42-42 (HK001200-01)

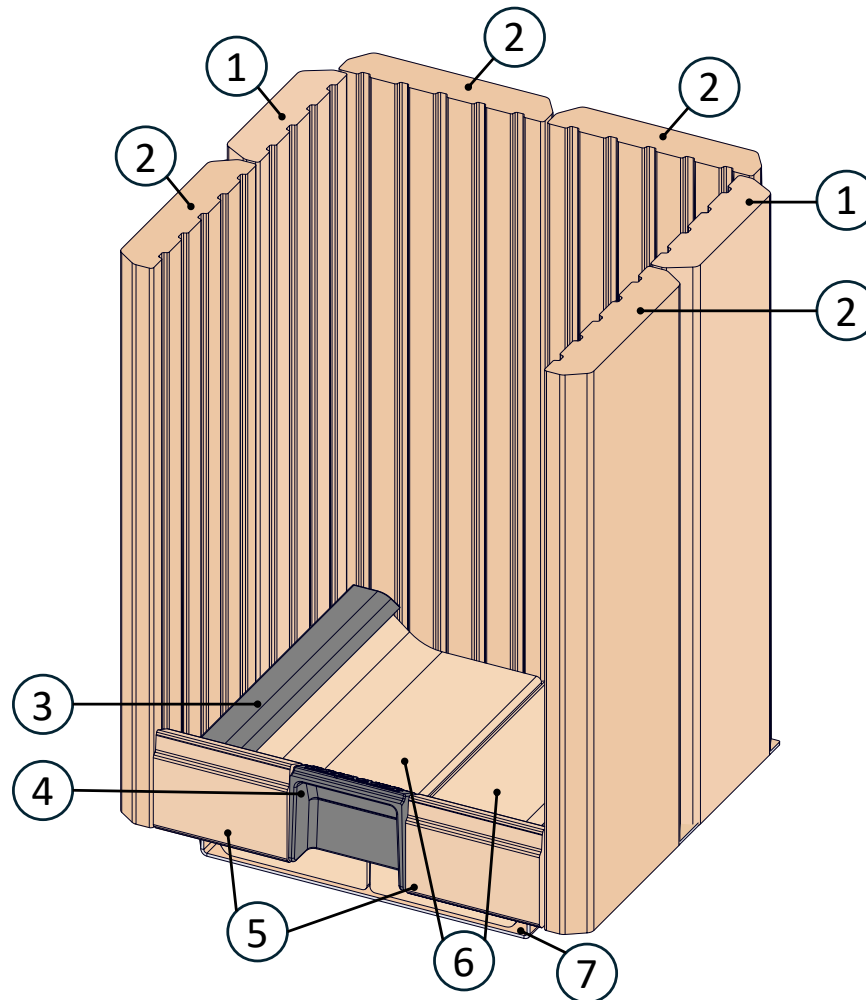

Position	Designation	Art.-Nr.	Pcs.
1	Stone 572x173x40	HK000011	2
2	Stone 572x203x40	HK000012	4
3	Cast air distributor	HK000006	2
4	Cast inlay front	HK000007	1
5	Wedge stone 132x99x40	HK001204	2
6	Bottom stone	HK001206	2
7	Bottom insulation	HK001207	1



Chamotte inner lining to be installed dry

3.6.2 COMBUSTION CHAMBER INNER LINING CAST IRON

flat 42-42 (HK001200-02)

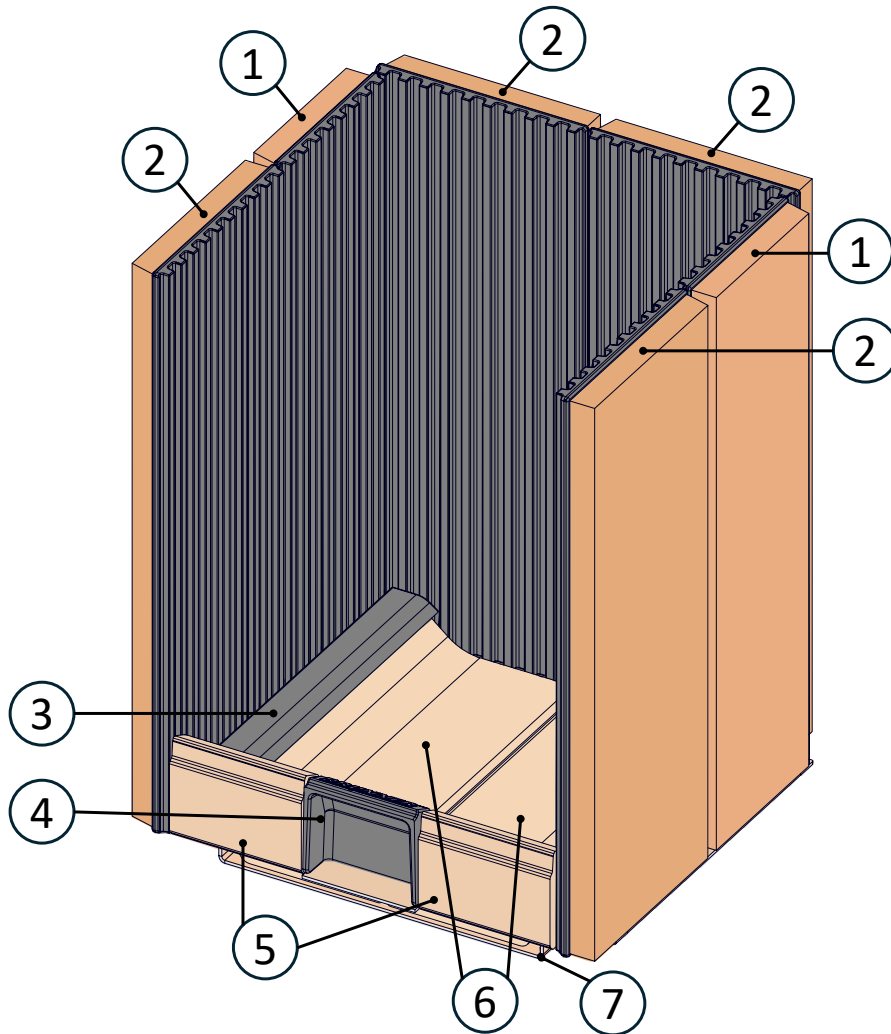

Position	Designation	Art.-Nr.	Pcs.
1	BG Cast iron plate 572x174x40	HK000174	2
2	BG Cast iron plate 572x210x40	HK000173	4
3	Cast air distributor	HK000006	2
4	Cast inlay front	HK000007	1
5	Wedge stone 132x99x40	HK001204	2

Position	Designation	Art.-Nr.	Pcs.
6	Bottom stone	HK001206	2
7	Bottom insulation	HK001207	1

3.7 VARIANT SUPPLY AIR CONNECTION BOX Ø 125 MM

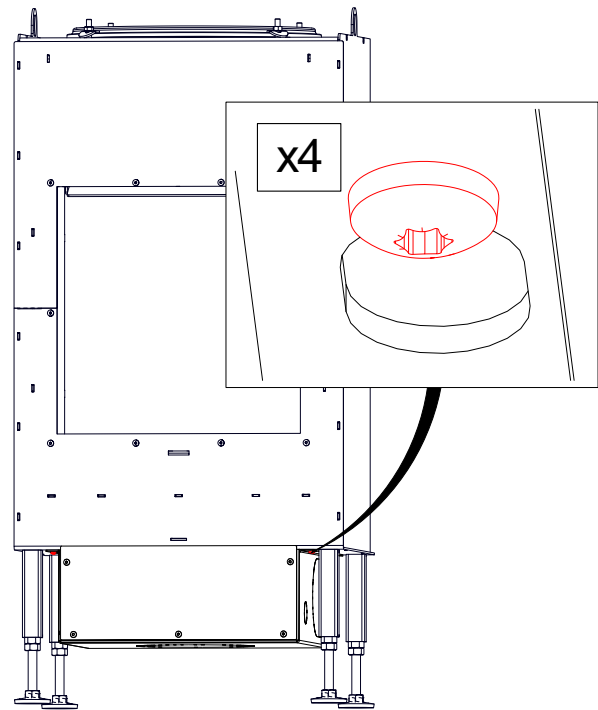
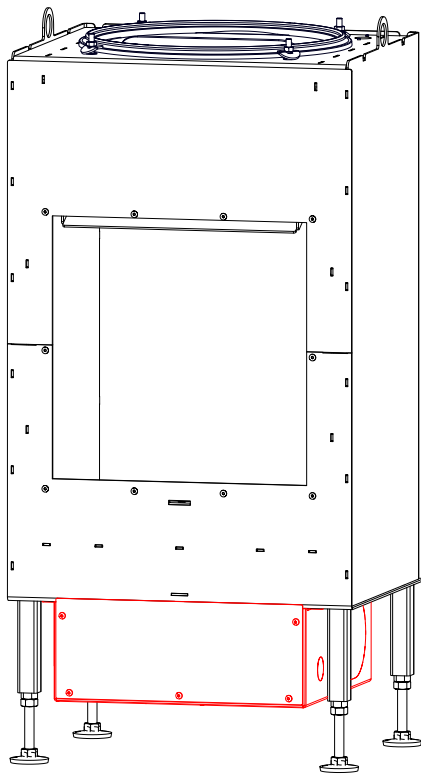
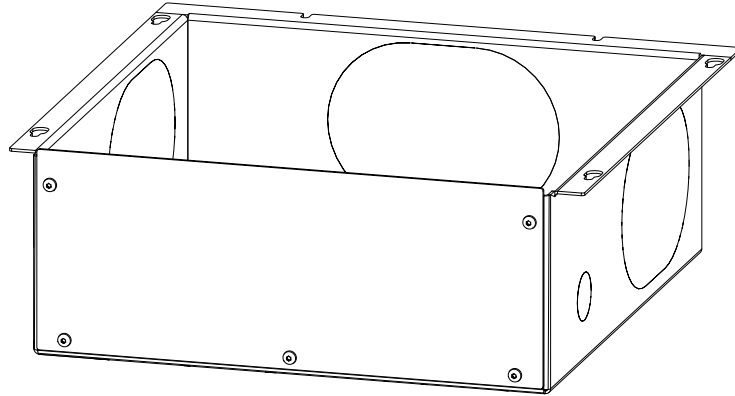

3.8 VARIANTS HEAT EXCHANGER

3.8.1 CAST IRON HEAT EXCHANGER RINGS

3.8.1.1 COMPONENTS SET 2 HEAT EXCHANGER RINGS

SET cast heat exchanger ring (R015006-02)

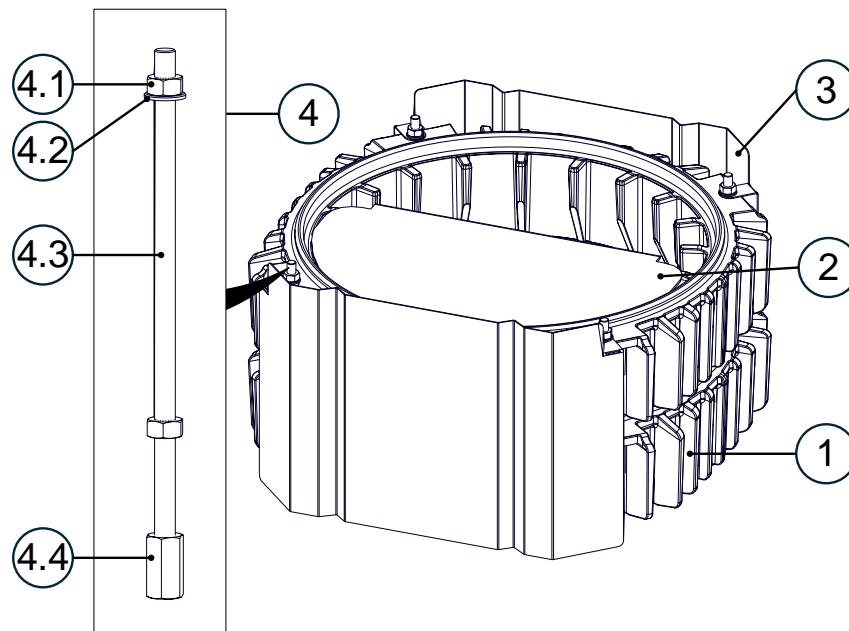

Position	Designation	Item no.	Pcs.
1	Cast iron heat exchanger ring	R015002	2
2	Heat exchanger baffle	R015003	2
3	Heat protection plate MRG	HK000298	4
4	Threaded rod M8x200	R015008	1
4.1	Hexagon nut	800202	8
4.2	Washer	00605	4
4.3	Threaded rod	R015007	4
4.4	Hexagon nut, long	800755	4

3.8.1.2 FITTING THE HEAT EXCHANGER RINGS

Work steps

- ▶ Screw on the long nuts.

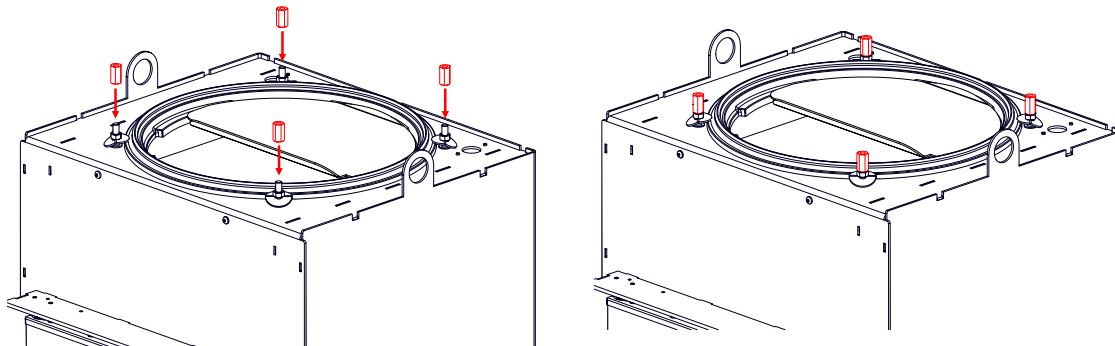

- ▶ Screw in the threaded rods.

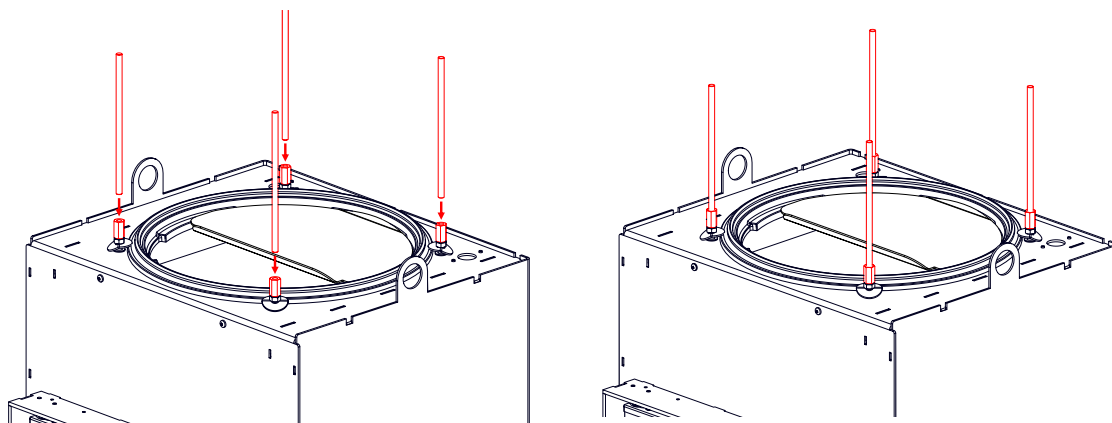

- ▶ Fit the bottom heat exchanger ring with deflector.

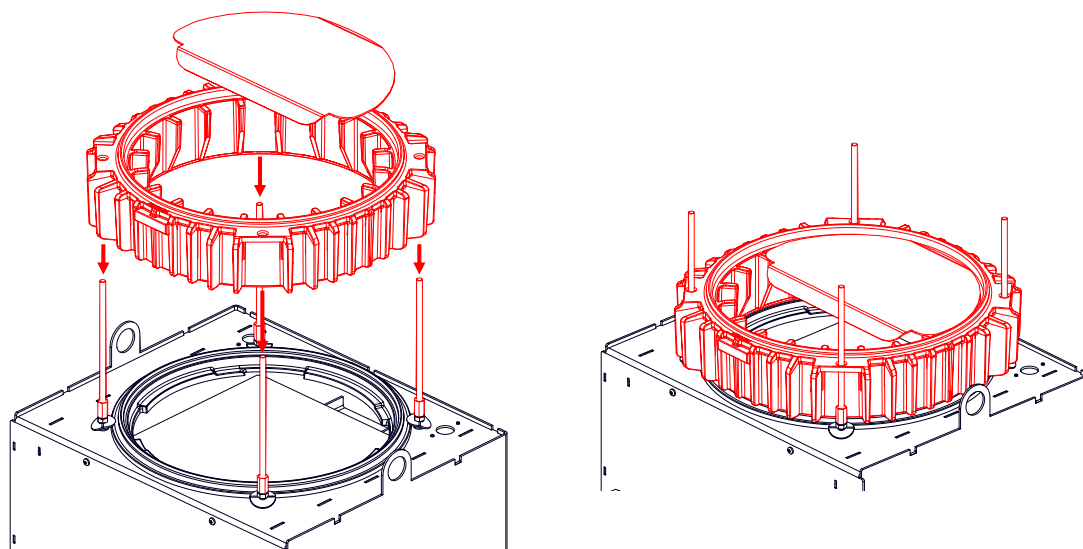

- ▶ Fit heat exchanger ring with deflector.

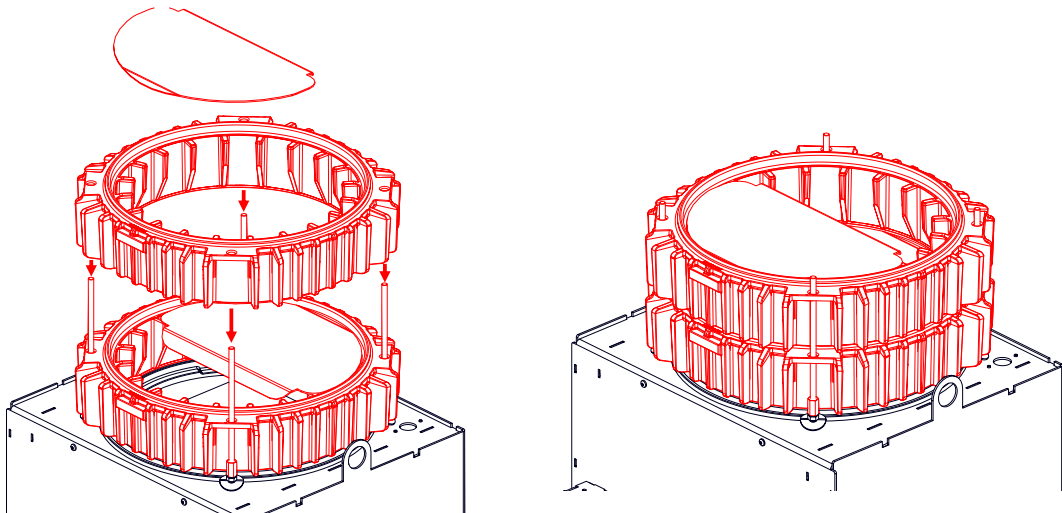

► Fit the set of heat protection plates.

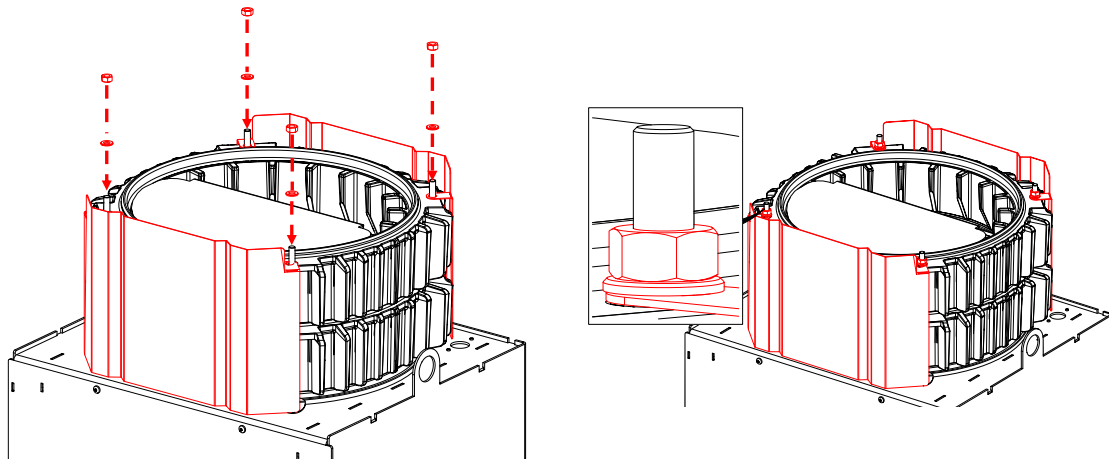

Assembly with 2+ heat exchanger rings

► Screw on the long nuts. Screw in threaded rods.

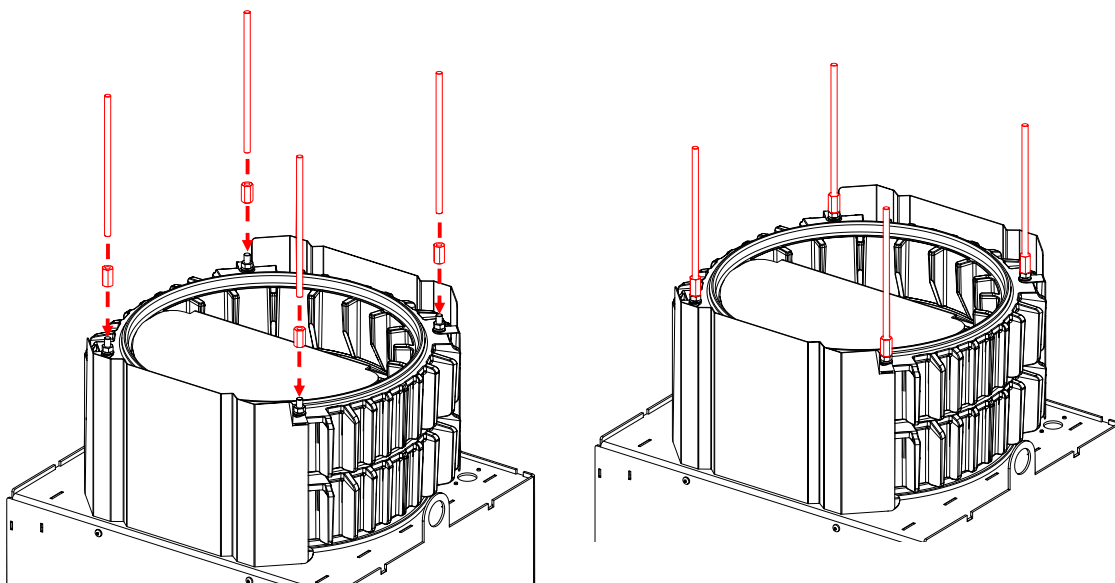

- Screw nuts onto threaded rods.

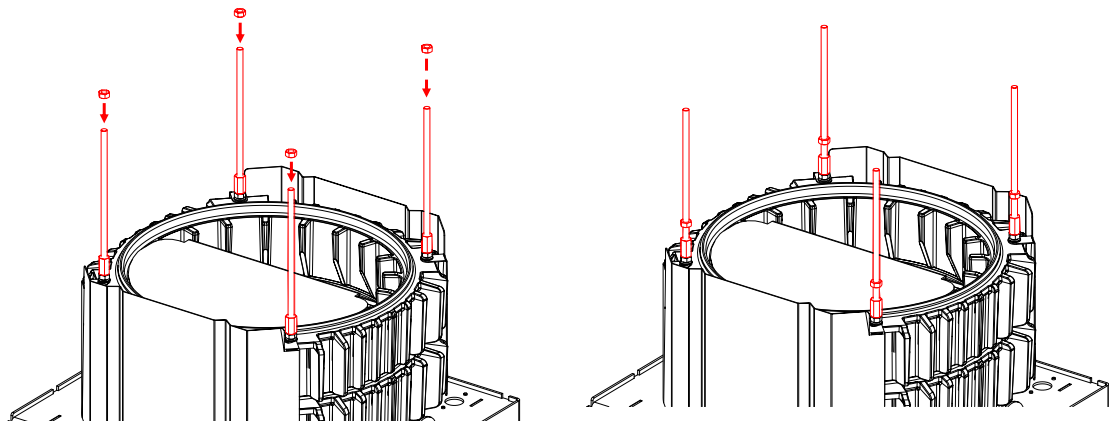

- Slide on the set of heat protection plates.

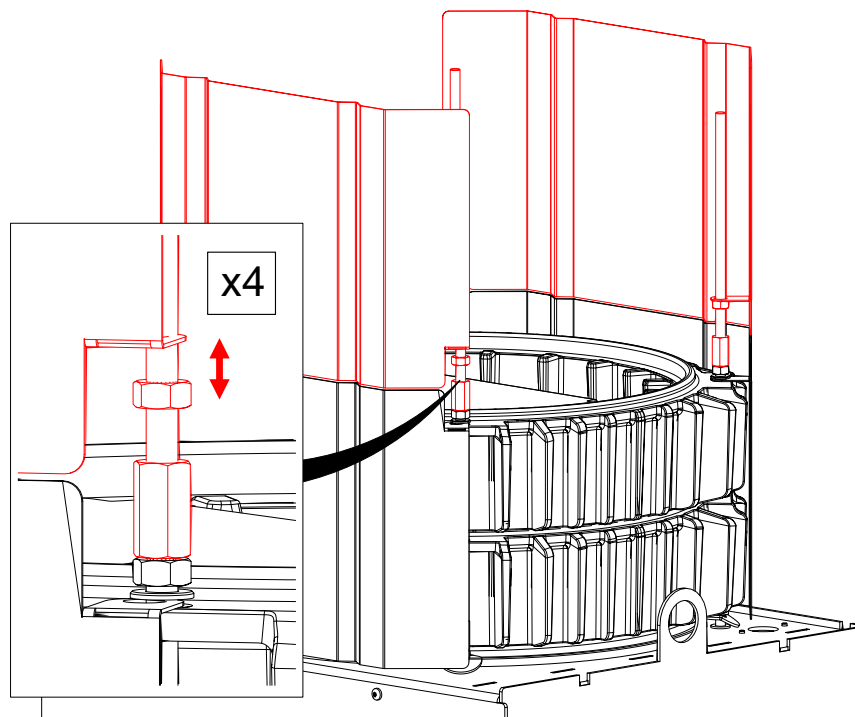

- Adjust the nuts so that there is a gap of approx. 4 mm between the heat protection plate at the top and the heat protection plate.

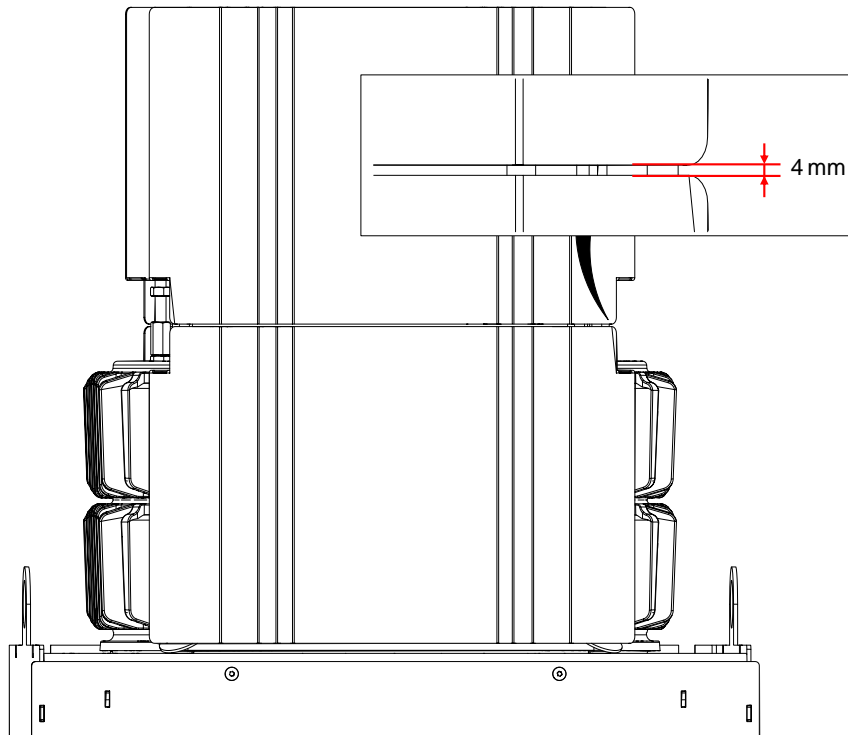

- Screw on the nuts to secure the heat protection plates.

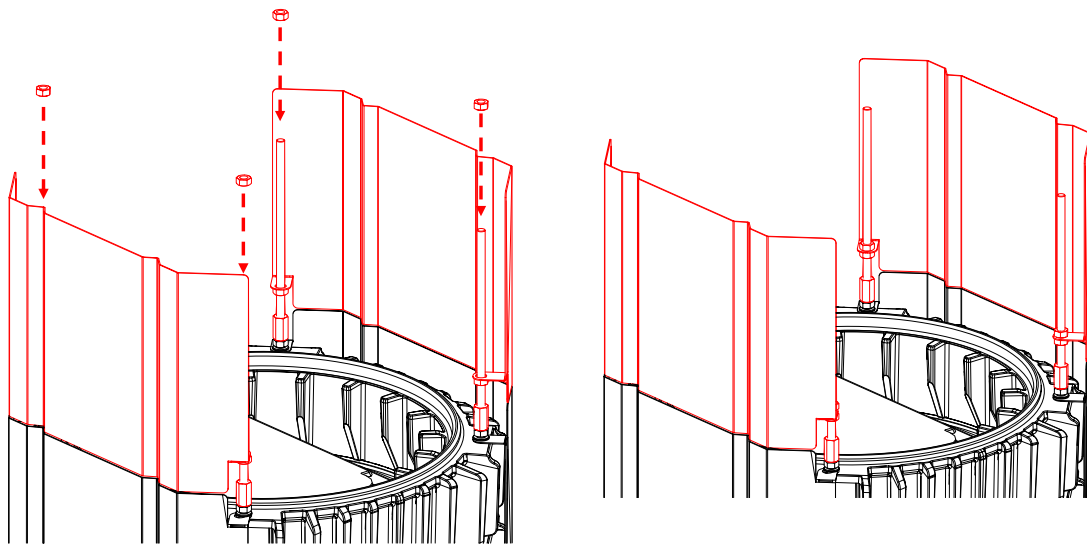

- Fit the heat exchanger ring with deflector.

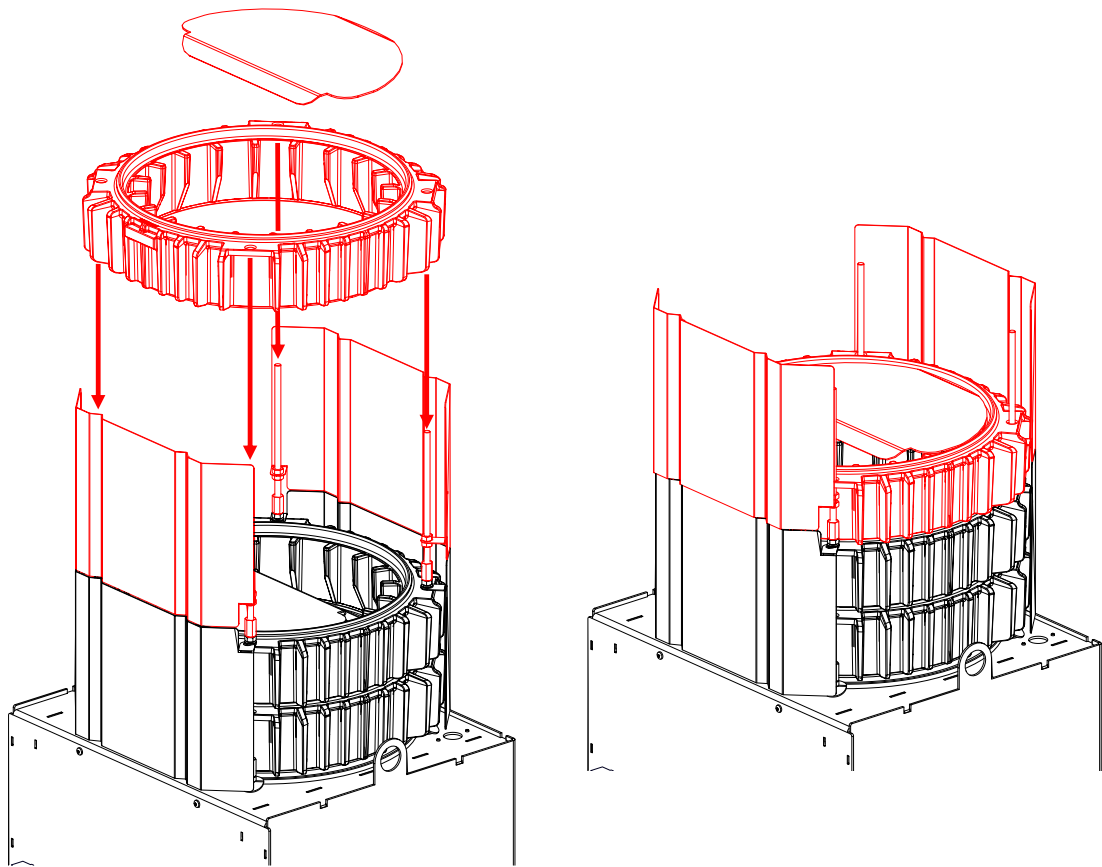

► Fit heat exchanger ring with deflector.

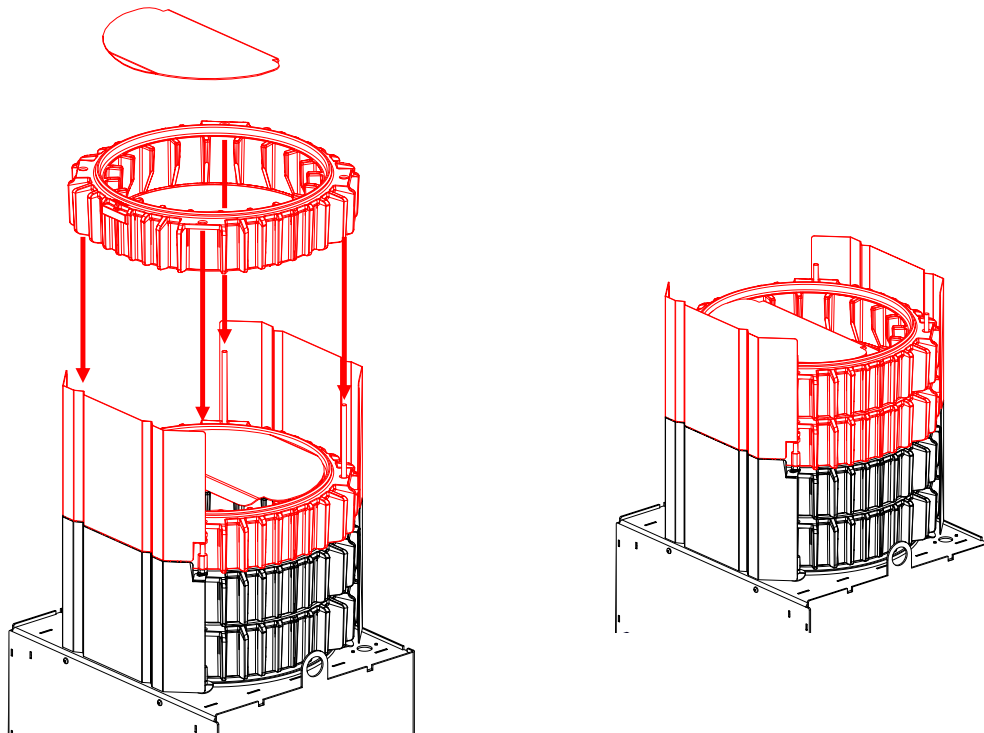

- Fit the top heat exchanger ring. Mount crosswise with washers and nuts and then tighten.

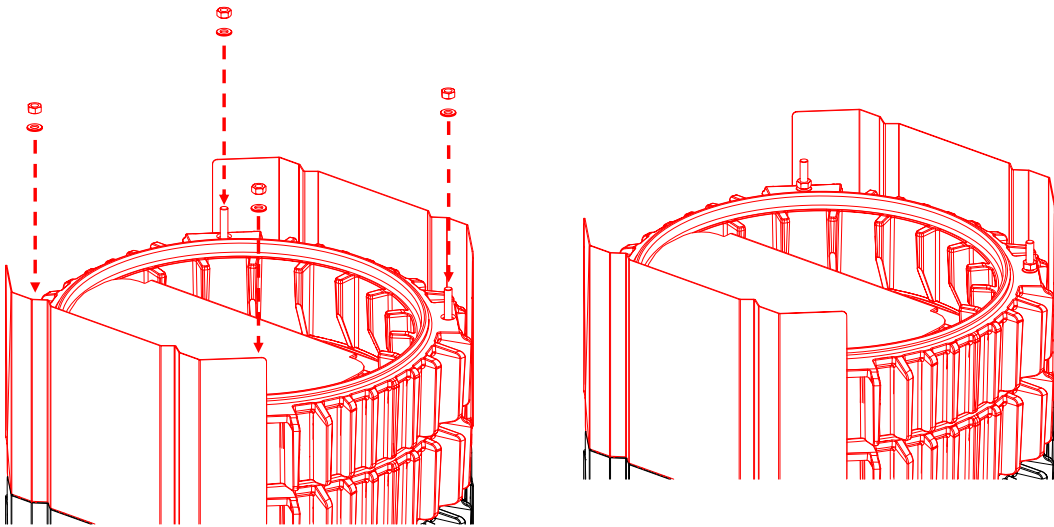

3.8.2 MAS

3.8.2.1 COMPONENTS MAS

MAS modular top-mount storage SET 440 (R009021-01)

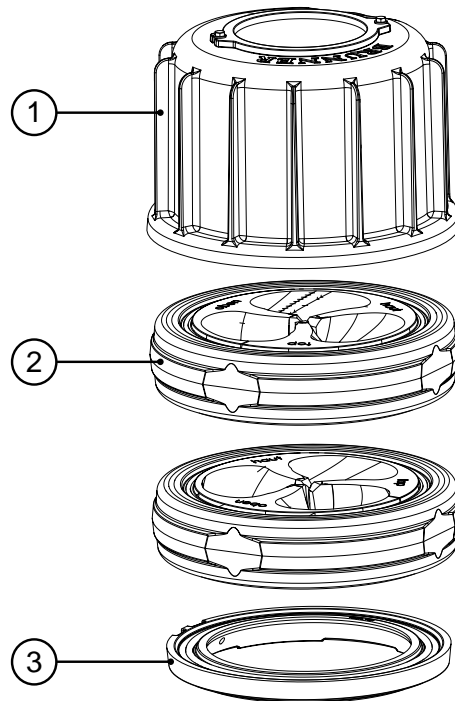

Position	Designation	Art.-Nr.	Pcs.
1	Cast iron dome	R009095-03	1
2	MAS 440 accumulation stone double-layered	R009042	2
3	Mounting ring	10077	1

3.8.2.2 MAS ASSEMBLY

Work steps

- ▶ Remove the deflector.

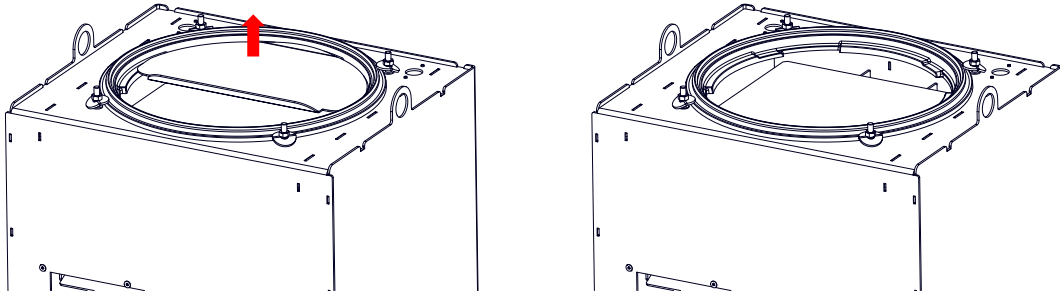

- ▶ Place the intermediate ring on the fitted KAT retaining ring.

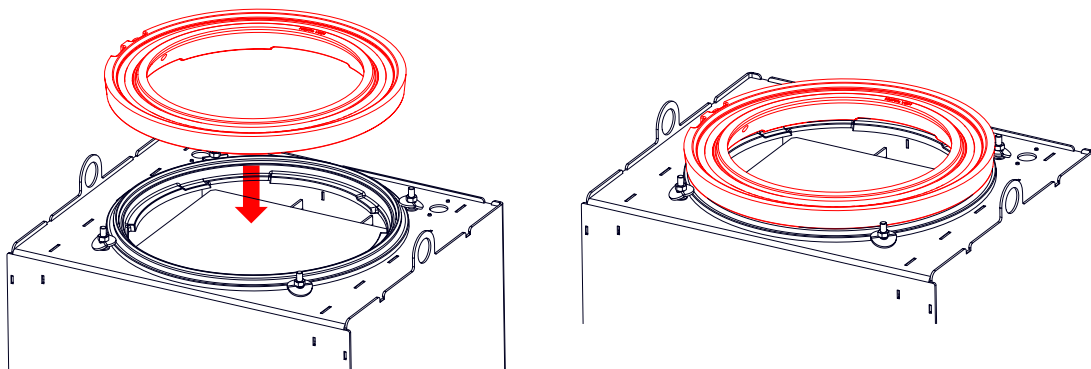

- ▶ Place the lowest storage ring in position.

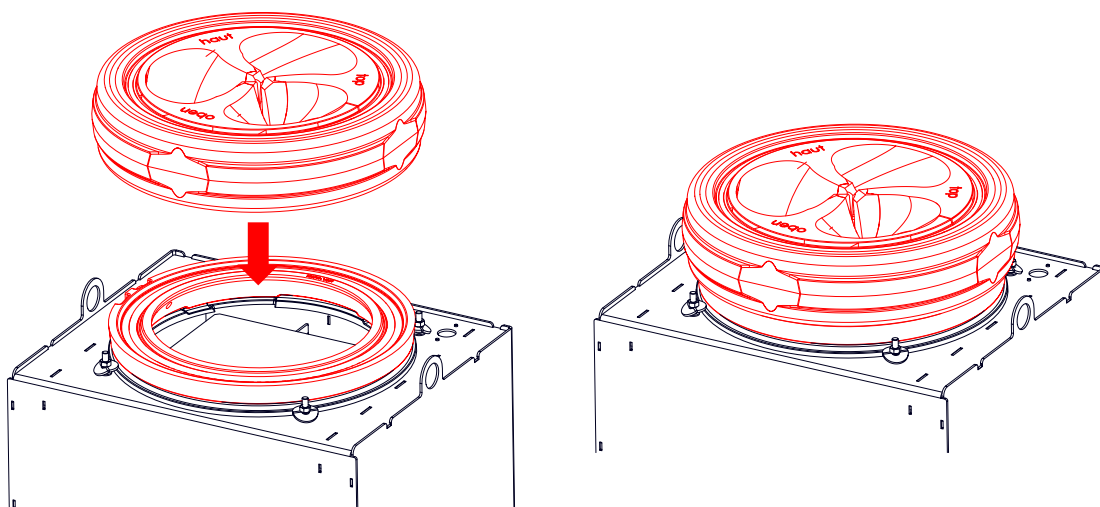

- ▶ Place additional storage ring on top. Then fit the cast iron cover.

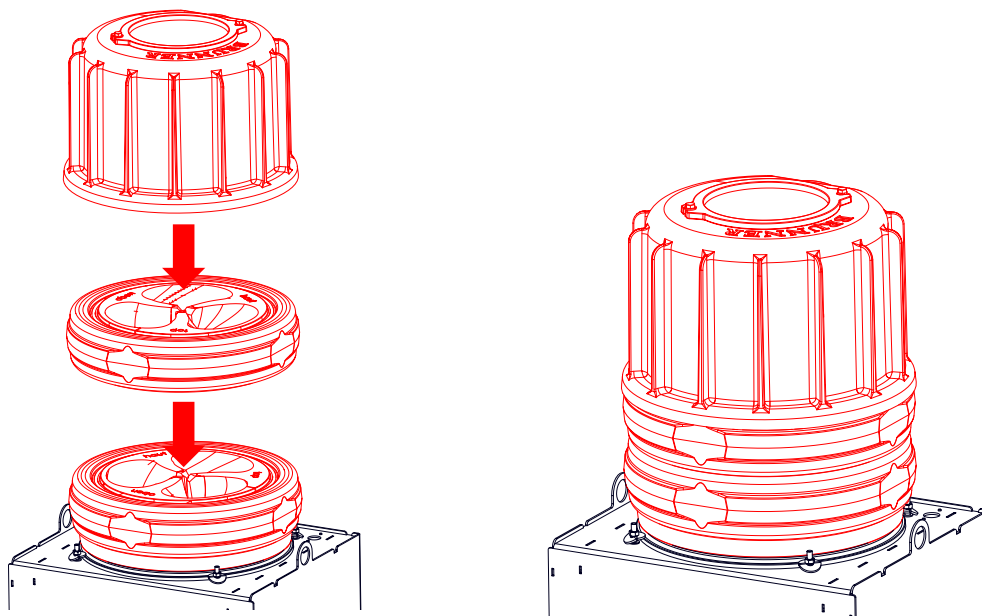

3.9 VARIANT EAS OR EOS

3.9.1 BOTTOM COVER AIR BOX EOS

3.9.1.1 COMPONENTS EOS

BG Bottom cover Air box small, EOS (HK000064)

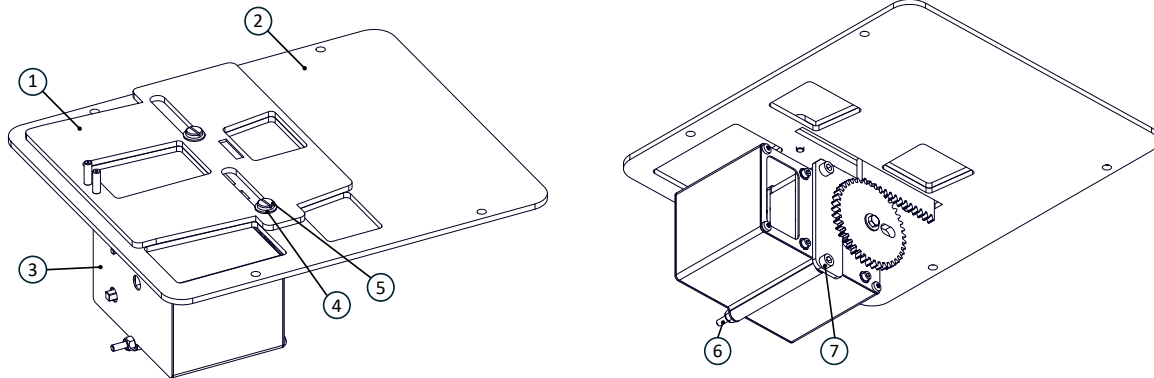

Position	Designation	Art.-Nr.	Stk.
1	Air slider plate small EOS	HK000232	1
2	BG Bottom cover Air box small EOS	HK000219	1
3	BG Servomotor EOS with Gear wheel	N003157	1
4	Collar bushing	I007337	2
5	Flat head screw (M5x6)	800461	2
6	hexagon nut with Clamping part	800155	2
7	Cylinder head screw (M5x100)	800035	2

3.9.1.2 FITTING: EOS

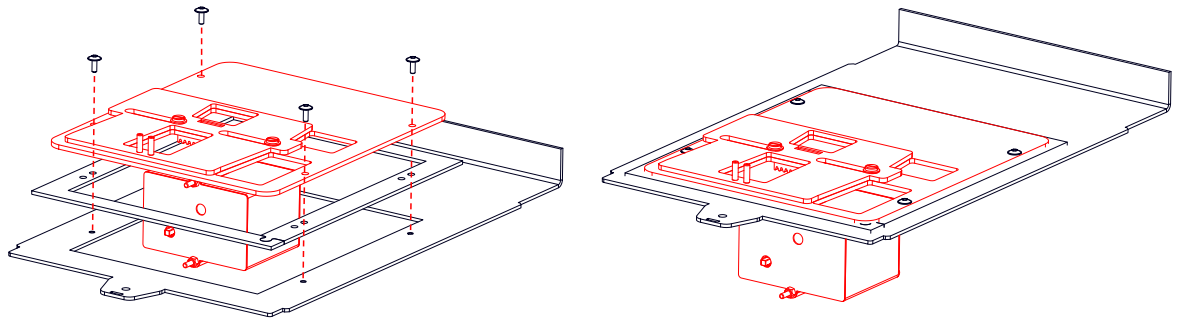

1

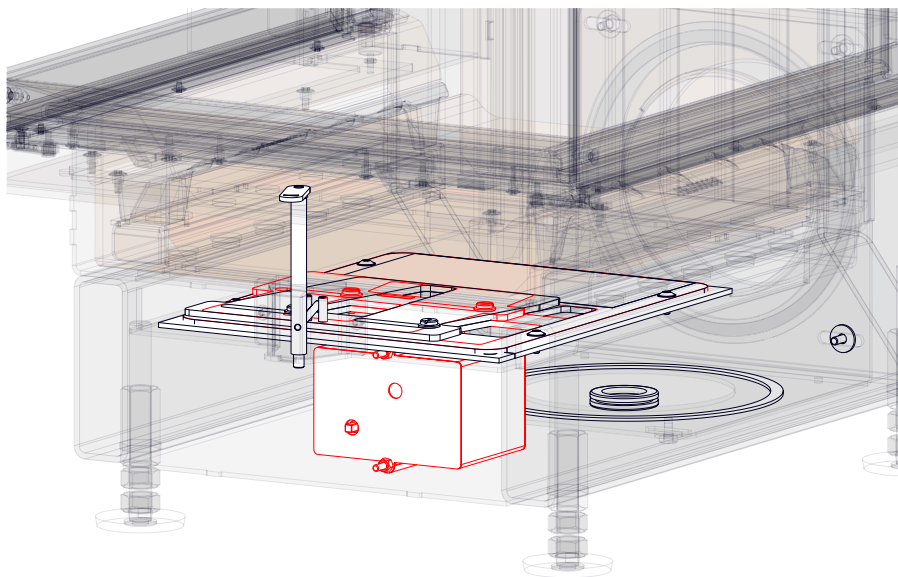
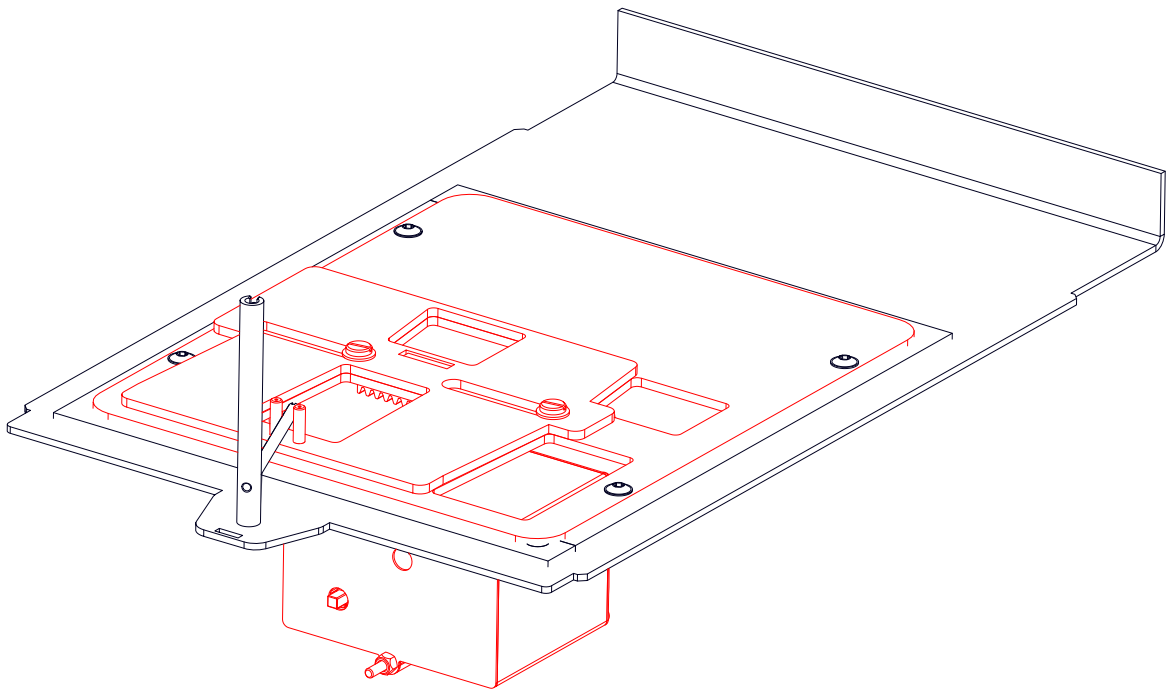

3.9.1.3 MEMBRANE FEED-THROUGH

Membrane feed-through (901248-01)

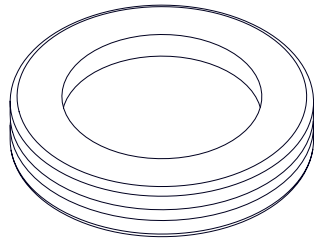

Position

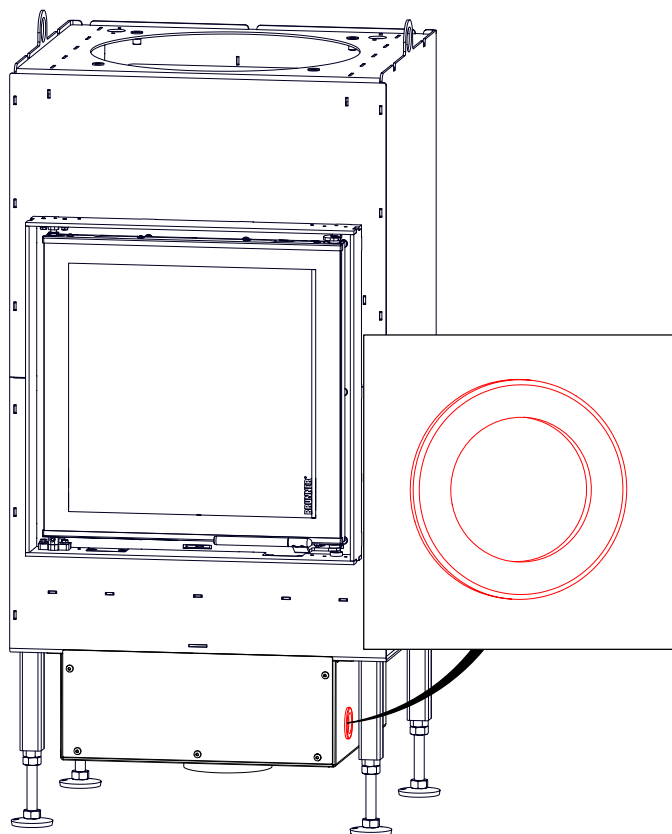

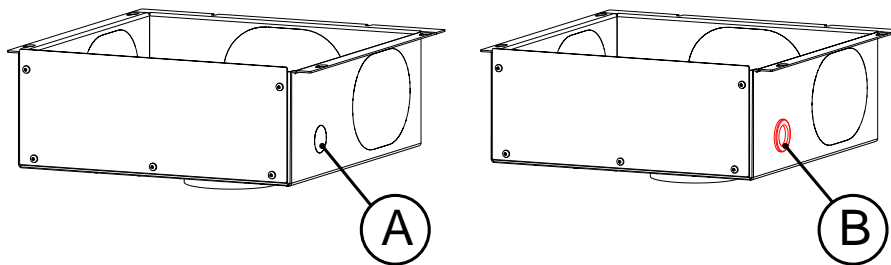

A = BKH

B = BKH with EOS

3.9.1.4 AIR POSITION INDICATOR BKH FLAT

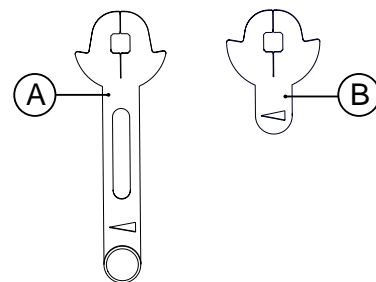
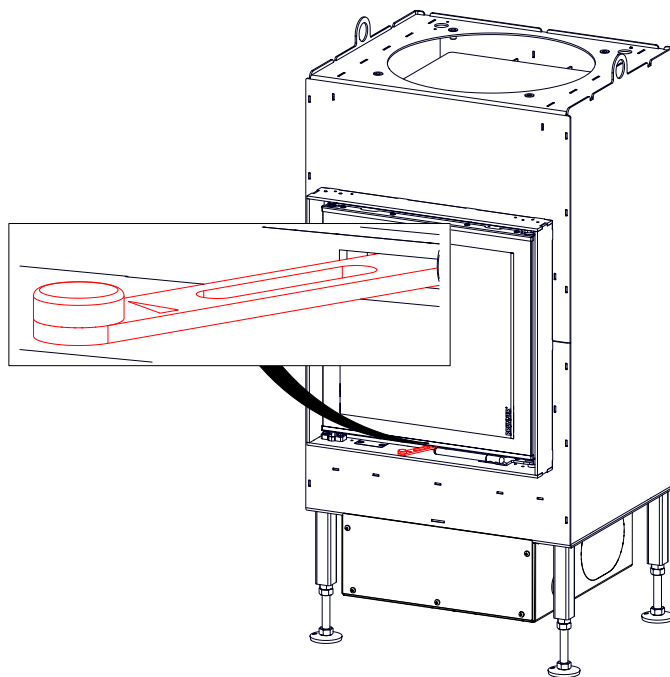

A = BKH flat

B = BKH flat with EOS

3.9.2 EAS3

3.9.2.1 COMPONENTS EAS

EAS3 (E005018)

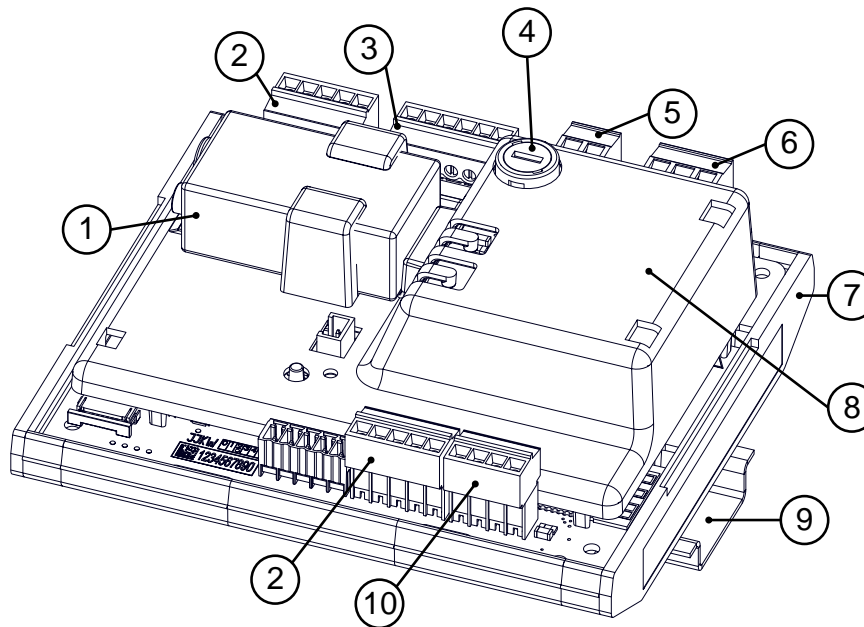

Position	Designation	Art.-Nr.	Stk.
1	Battery 9V	00937	1
2	Socket plug	900077	2
3	Socket plug	900078	1
4	Circuit board EAS3	903279	1
5	Socket plug	900079	1
6	Socket plug	900070	1
7	Housing	900339	1
8	Cover	903282	1
9	Mounting rail	900338	1
10	Socket plug	900074	1

3.9.2.2 FITTING: EAS

Position

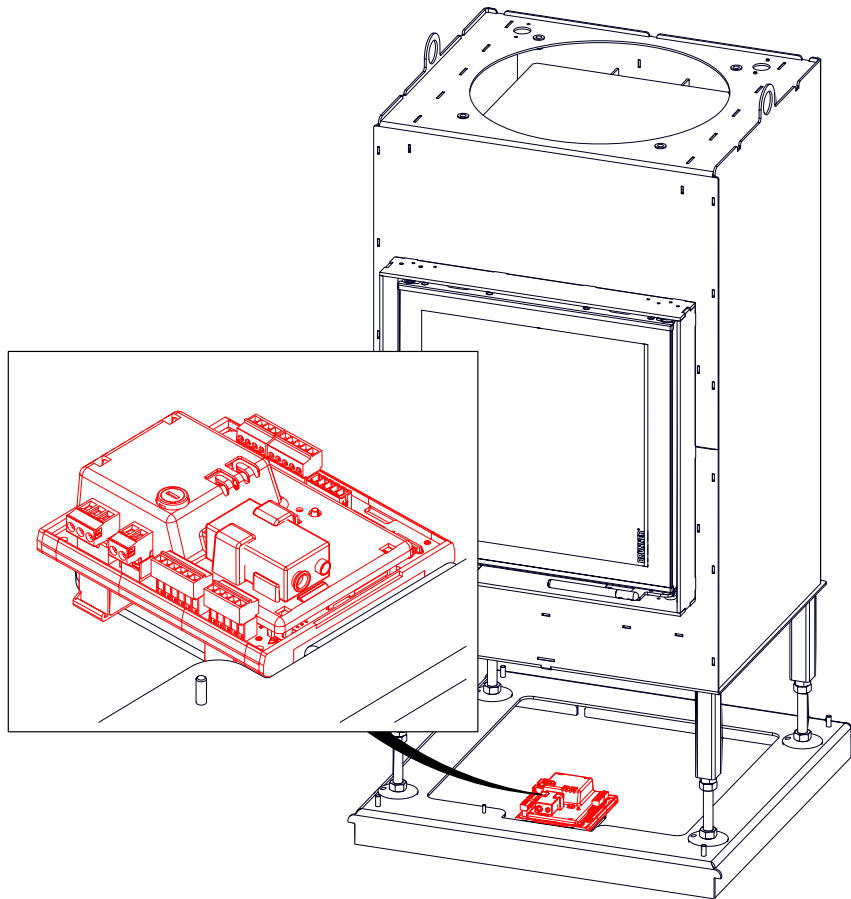

Workflow

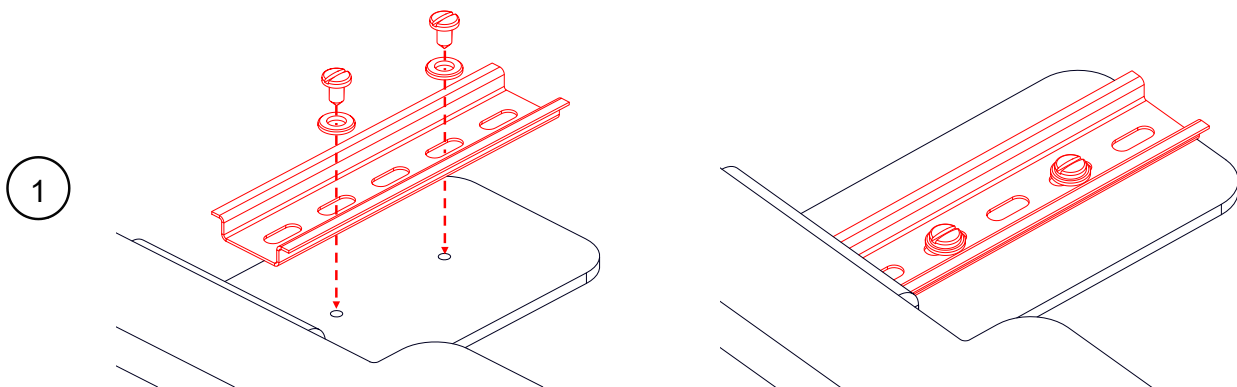

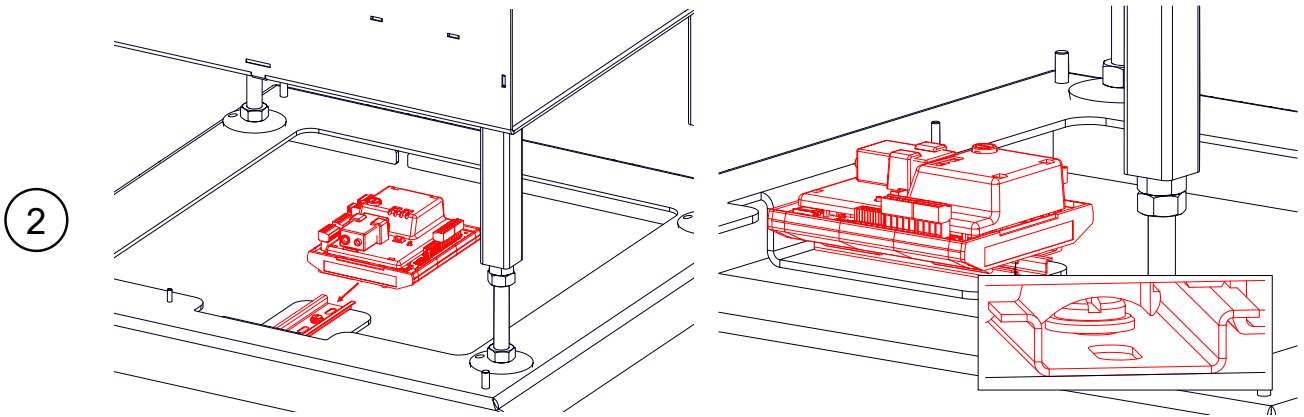

3.9.3 THERMOCOUPLE

3.9.3.1 COMPONENTS THERMOCOUPLE

BG Thermocouple with Retaining plate (HK000095)

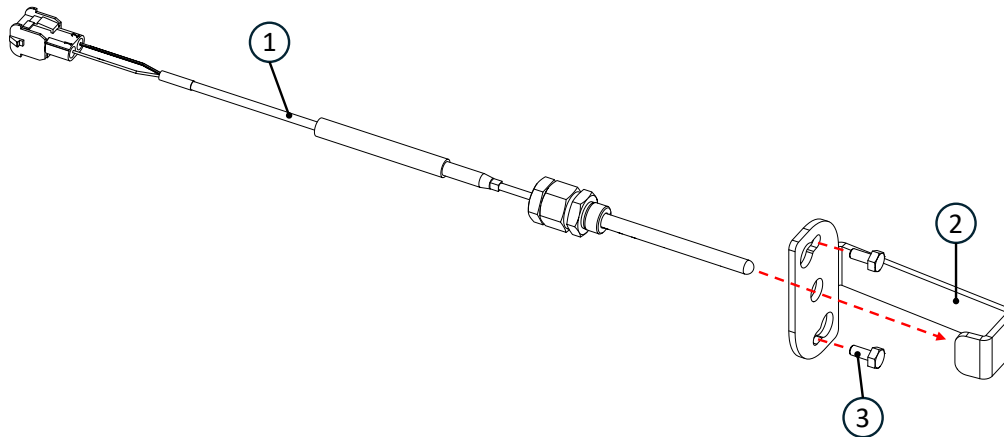

Position	Designation	Art.-Nr.	Pcs.
1	BG Thermocouple	10992.1	1
2	Thermocouple Retaining plate	HK000216	1
3	Hexagon head screw (M5x10)	02531	2

3.9.3.2 FITTING: THERMOCOUPLE

Position

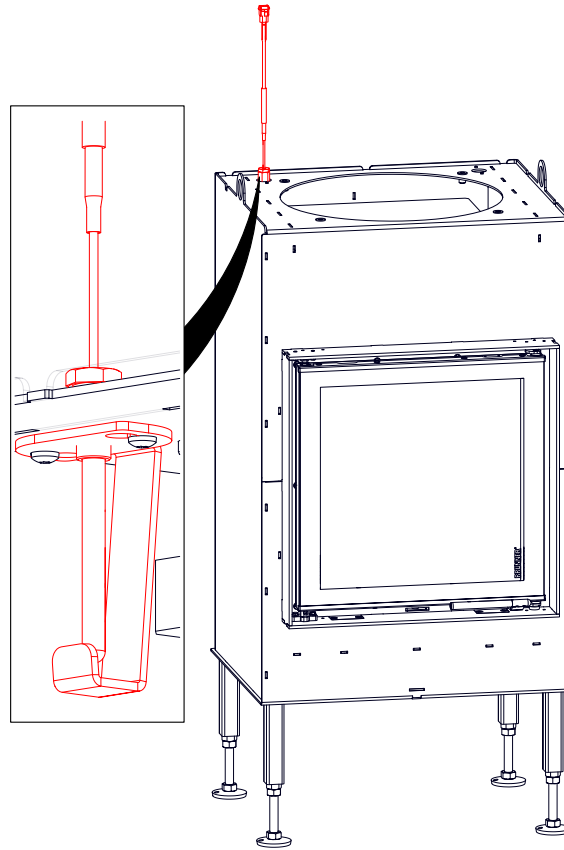

Workflow

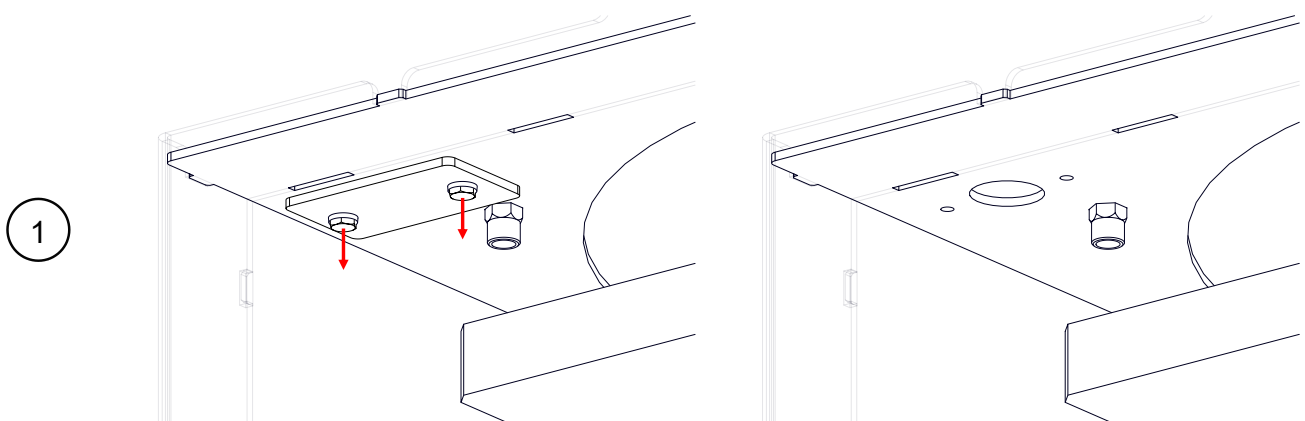

2

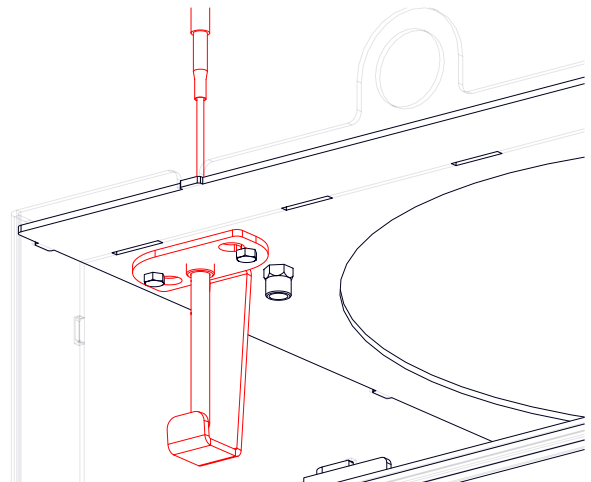
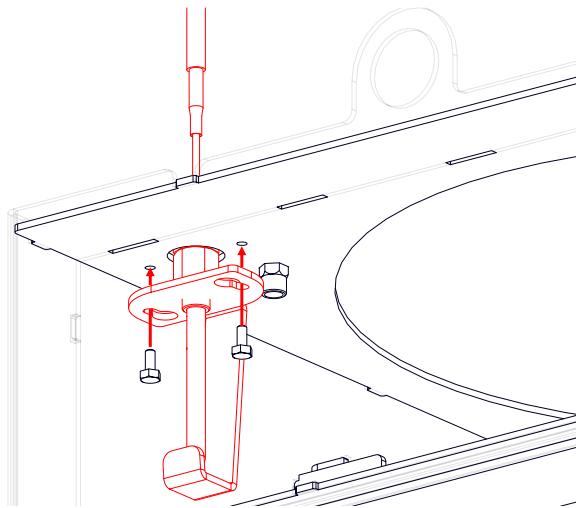

**Variant: Ther-
mocouple
right side**

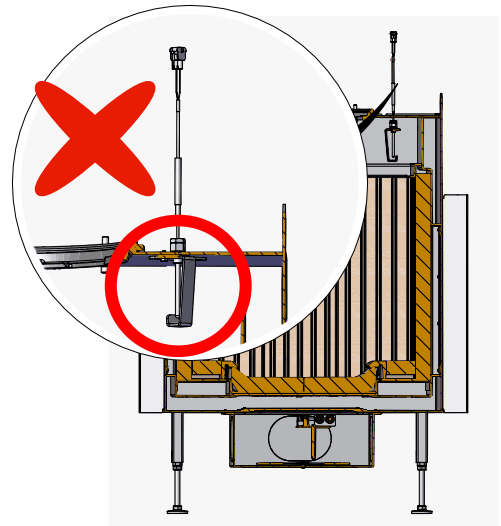
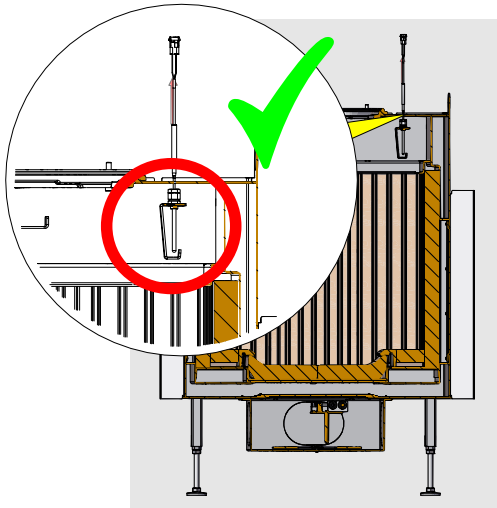

**Variant: Ther-
mocouple
left side**

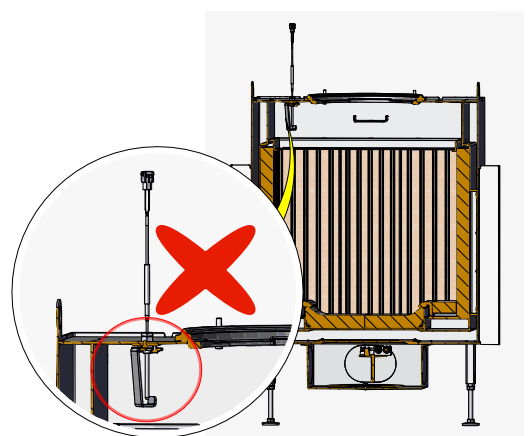
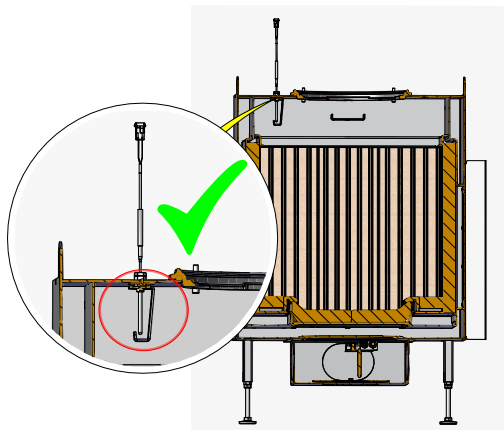

3.9.4 DOOR CONTACT SWITCH

3.9.4.1 COMPONENTS DOOR CONTACT SWITCH

Door contact switch (E011001)

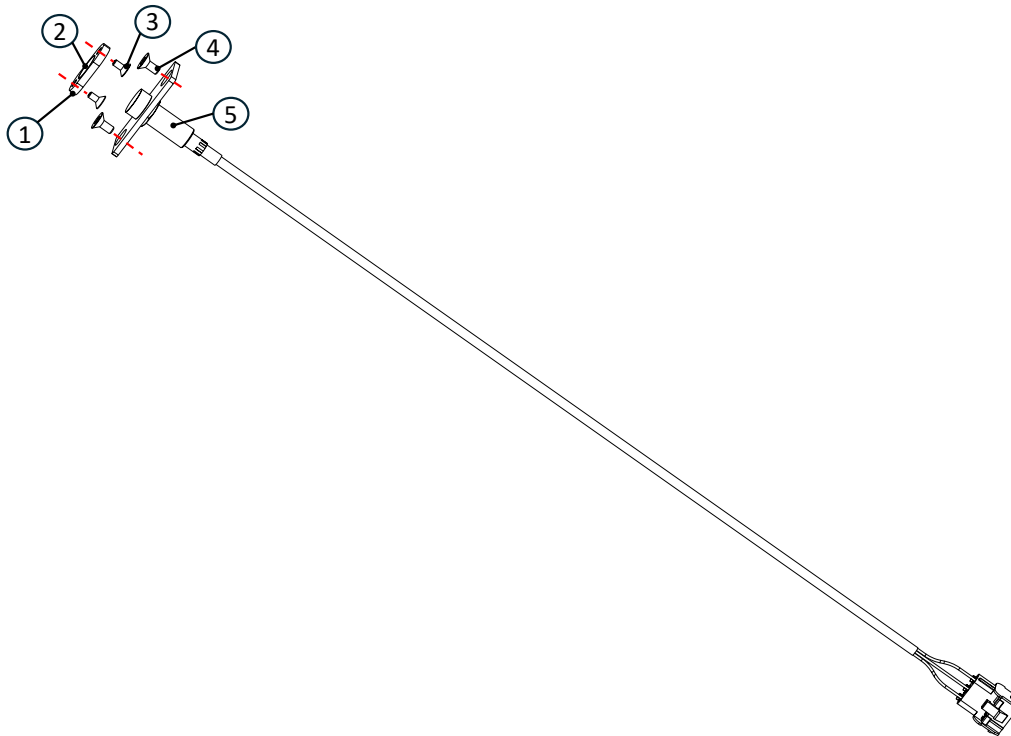

Position	Designation	Art.-Nr.	Pcs.
1	Retaining plate Magnet	E011011	1
2	Magnet	903324	1
3	Countersunk screw (M4x8)	800063	2
4	Countersunk screw (M5x10)	800184	2
5	BG Door contact switch	E011003	1

3.9.4.2 FITTING: DOOR CONTACT SWITCH

Position

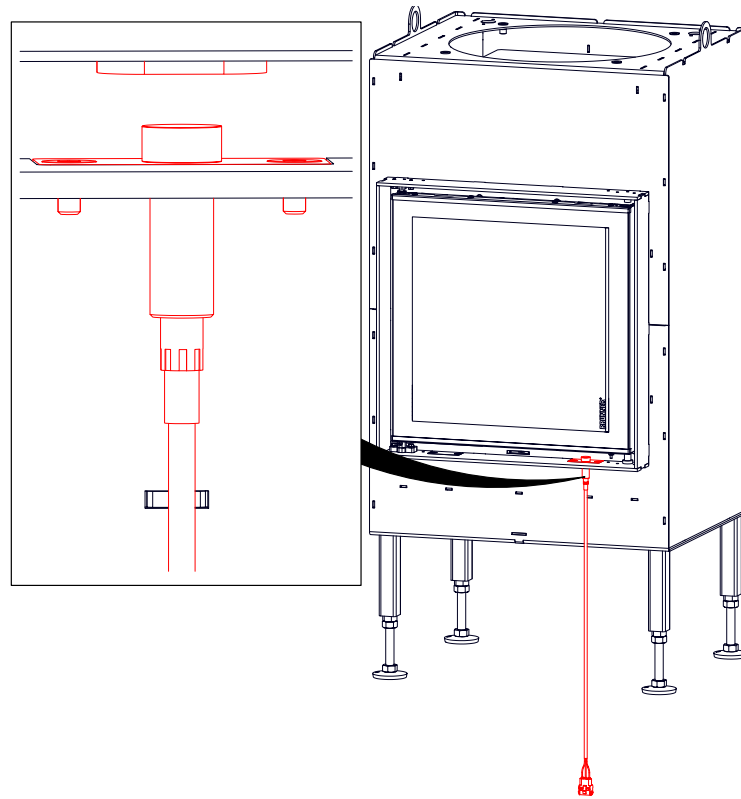

Workflow

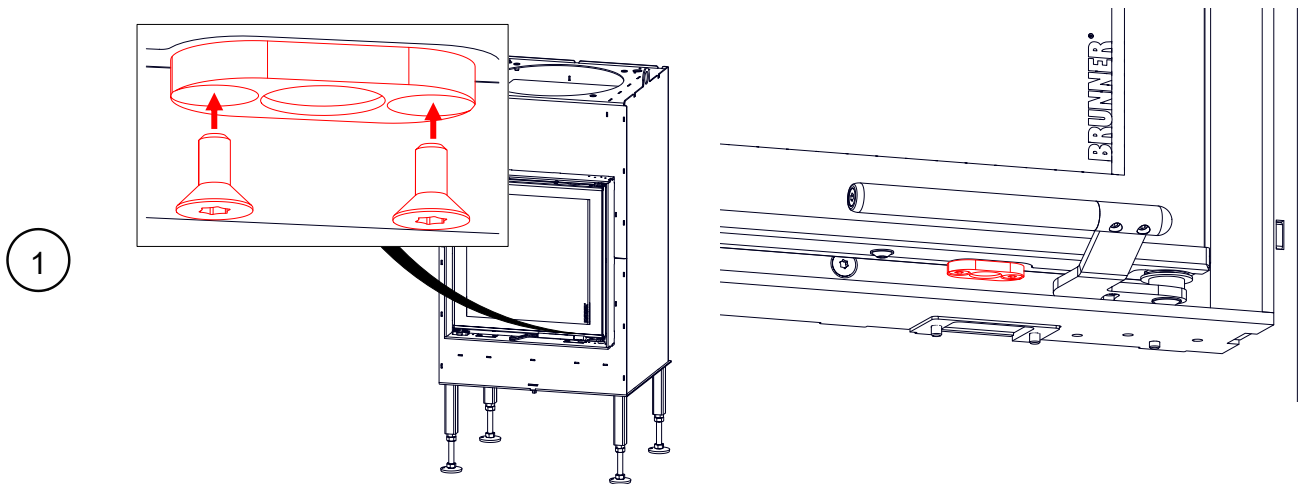

2

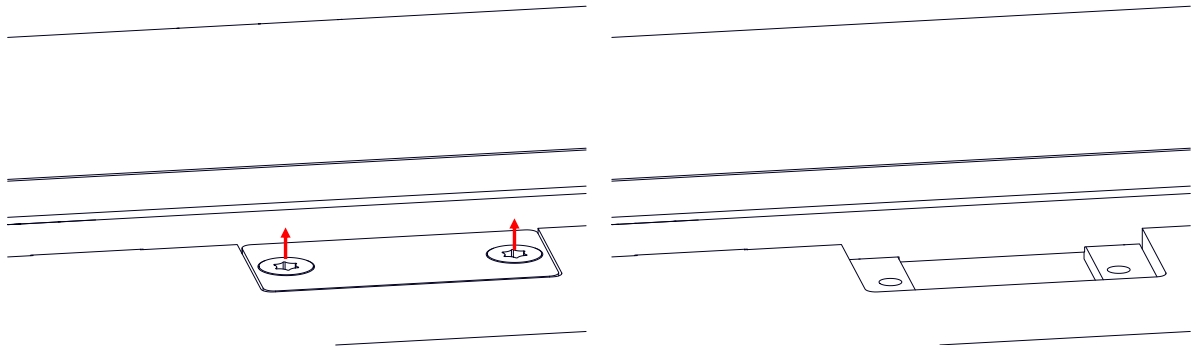

3

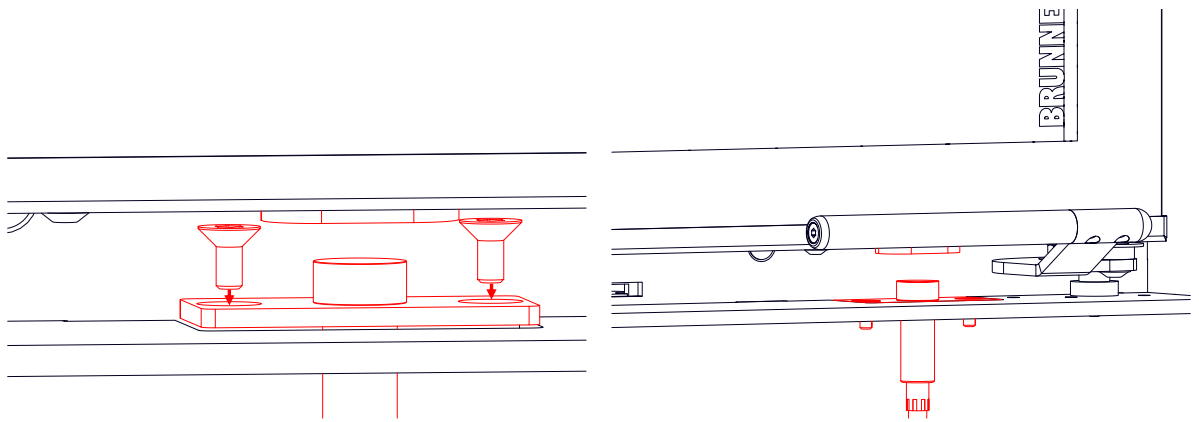

Dimension sheets - BKO 42-42

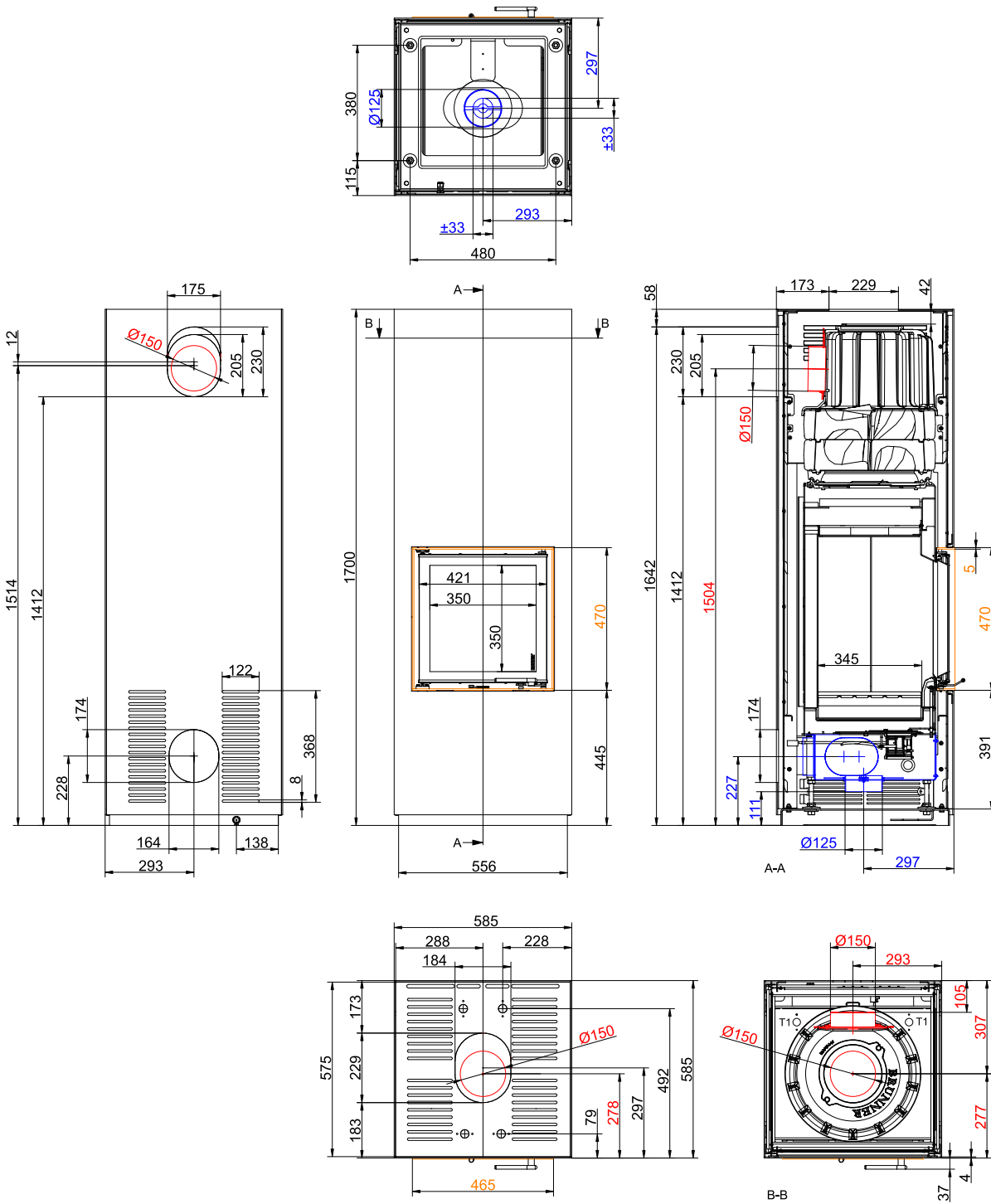

...MAS

We suggest for CAD planning Palette CAD. Permanent updated drawings: www.brunner.de
 Frames/ flue gas outlet connection/ combustion air supply connection/ front variants/ support bearing are marked in color.

Planning and installation - BKO 42-42

Tested according to		EN 13240
Data for functional demonstration		
Rated heat power	kW	7
Fire wood volume	kg/h	2.1
Flue gas mass flow	g/s	7.5
Flue gas temperature	°C	220
Necessary supply pressure ¹⁾	Pa	12
Combustion air consumption	m ³ /h	18
Combustion air connection Ø	mm	125
Cladding components ²⁾		
Foot print (W x D)	mm	585 x 585
Overall height	mm	1700
Minimal distances		
to mounting wall	cm	5
to combustible mounting wall	cm	5
to mounting floor	cm	0
from top of fireplace to ceiling (d _c)	cm	60
Cross-section of gratings		
exhaust warm air	cm ²	463
Recirculation air	cm ²	420
Minimum distances in the radiation area, glass ceramic / glass ceramic coated (GKB)		
in the radiation area (d _{RP})	cm	120 / 80
in the floor area (d _{FP})	cm	40 / 27
in the side wall area (d _{SL})	cm	60 / 40
Weight		
Insert	kg	158
Total weight	kg	423
Meets requirement/limit values for:		
EU / Germany	Ökodesign / 1. BImSchV (Stufe 2)	

1) Damper flap recommended

2) Characteristics of raw steel ("black steel"):

Untreated steel with an individual, irregular surface and visible signs of use (welding discoloration, manufacturing marks and unevenness).

Rolled at approx. 1200 degrees Celsius - this creates a natural scale layer with an individual patina - deliberately untreated for an authentic look.

Surface requirements: Class A1 in accordance with EN 10163-2:2004. Material or production-related irregularities ("imperfections") with a depth of up to 0.2 mm are unavoidable due to the production process and therefore not worthy of complaint. Any imperfections can only be classified as (material) defects if the limit value of 0.4 mm depth is exceeded and the affected zone of the respective cladding part is checked.

Only suitable for indoor use.

Product data sheet according to (EU) 2015/1186:

Supplier's name or trademark	Ulrich Brunner GmbH
Model identifier:	BKH 5.0 Flach 42-42 green DT
Energy efficiency class:	A+
Direct heat output:	7,0 kW
Indirect heat output:	N.A. kW
Energy efficiency index:	115,7
Fuel energy efficiency (at nominal heat output):	87,0 %
Fuel energy efficiency (at minimum load):	N.A. %
Special precautions: see supplied product documentation	

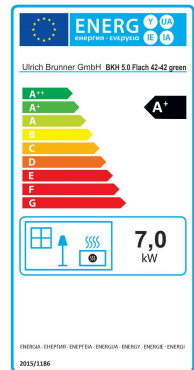
**Ulrich Brunner GmbH**

Zellhuber Ring 17-18

D-84307 Eggenfelden

Phone: +49 (0) 8721/771-800

E-Mail: info@brunner.de

Copyright

All information, drawings and technical descriptions contained in this documentation are our property and may not be reproduced without prior written permission.

® **BRUNNER** is a registered trademark.

Subject to technical changes and errors.

© by Ulrich Brunner GmbH

Doku-Nr.: 203074